

# sBot Speed CIP – FA

Safety System

**SICK**  
Sensor Intelligence.



---

**Described product**

sBot Speed CIP – FA

**Manufacturer**

SICK AG  
Erwin-Sick-Str. 1  
79183 Waldkirch  
Germany

**Legal information**

This work is protected by copyright. Any rights derived from the copyright shall be reserved for SICK AG. Reproduction of this document or parts of this document is only permissible within the limits of the legal determination of Copyright Law. Any modification, abridgment or translation of this document is prohibited without the express written permission of SICK AG.

The trademarks stated in this document are the property of their respective owner.

© SICK AG. All rights reserved.

**Original document**

This document is an original document of SICK AG.

## Contents

<b>1</b>	<b>About this document.....</b>	<b>6</b>
1.1	Purpose of this document.....	6
1.2	Scope.....	6
1.3	Target groups of these operating instructions.....	7
1.4	Symbols and document conventions.....	7
1.5	Terminology used.....	8
1.6	Further information.....	8
<b>2</b>	<b>Safety information.....</b>	<b>9</b>
2.1	General safety note.....	9
2.2	Intended use.....	9
2.3	Inappropriate use.....	9
2.4	Requirements for the qualification of personnel.....	9
2.5	Safe state of the safety outputs.....	10
<b>3</b>	<b>Product description.....</b>	<b>11</b>
3.1	Design of the overall system.....	11
3.2	Functionality.....	11
3.3	Requirements for the application.....	12
3.4	Product characteristics.....	12
3.4.1	Components.....	12
3.4.2	Human-robot interaction.....	13
3.4.3	Functions of the safety system.....	13
3.4.4	Automated restart.....	14
<b>4</b>	<b>Project planning.....</b>	<b>17</b>
4.1	Manufacturer of the overall system.....	17
4.1.1	Reasonably foreseeable misuse.....	17
4.2	Operating entity of the overall system.....	18
4.3	Design.....	18
4.3.1	Design of the access point to the hazardous area (example).....	18
4.3.2	Position of the safety laser scanner.....	18
4.3.3	Protective field design.....	21
4.3.3.1	Selecting the number of protective fields.....	21
4.3.3.2	Overlapping protective fields.....	23
4.3.3.3	Distance between the ends of protective fields PF1 and PF2.....	23
4.3.3.4	Minimum distances of protective fields PF1 and PF2 to the hazardous area.....	24
4.3.3.5	Minimum distance to the hazardous area for protective field PF3.....	29
4.3.4	Robot operating modes.....	30
4.3.5	Warning signs for automated restart.....	30
4.3.6	Emergency stop pushbutton requirements.....	30

4.3.7	Requirements for the reset pushbutton and restart button.	31
4.4	Integrating the equipment into the electrical control.....	31
4.4.1	Circuit diagram.....	31
4.5	Integration into the network.....	31
4.5.1	Interfaces.....	31
4.6	Configuration of the robot controller.....	33
4.7	Testing plan.....	37
<b>5</b>	<b>Mounting.....</b>	<b>38</b>
5.1	For mounting the components.....	38
<b>6</b>	<b>Electrical installation.....</b>	<b>39</b>
6.1	Electrical installation of the components.....	39
6.2	General requirements.....	39
6.3	Safety controller pin assignment.....	39
<b>7</b>	<b>Configuration.....</b>	<b>42</b>
7.1	Requirements for software and firmware.....	42
7.2	Pre-configured project files.....	42
7.3	Overview of the software structure.....	42
7.4	Opening project file.....	43
7.5	Connection overview.....	44
7.6	Main module configuration.....	44
7.6.1	Verifying the logic.....	44
7.6.2	Jump addresses.....	44
7.6.2.1	Finding source and destination jump addresses that belong together.....	44
7.6.3	In/out page.....	44
7.6.4	Emergency stop page.....	45
7.6.5	Protective stop page.....	45
7.6.6	SafetyRatedMonitoredSpeed page.....	46
7.6.7	SafeSequenceMonitoring page.....	46
7.6.8	Robot safety signals page.....	47
7.6.9	Non-secure robot signals page.....	47
7.7	Configuring the safety laser scanner.....	48
7.7.1	Resolution of the safety laser scanner.....	48
7.7.2	Field sets and cut-off paths.....	48
7.7.3	Configuring the safety system without protective field PF3..	48
7.8	Transfer configuration.....	48
<b>8</b>	<b>Commissioning.....</b>	<b>49</b>
8.1	Safety.....	49
8.2	Overview of commissioning.....	49
8.3	Putting the robot controller into operation.....	50
8.4	Configuring the safety network number in the robot controller.....	55
8.5	Check during commissioning and modifications.....	56

---

<b>9</b>	<b>Maintenance.....</b>	<b>57</b>
9.1	Maintenance of the components.....	57
<b>10</b>	<b>Troubleshooting.....</b>	<b>58</b>
10.1	Troubleshooting the components.....	58
10.2	Checking the network connection.....	58
<b>11</b>	<b>Operation.....</b>	<b>59</b>
11.1	Operating the components.....	59
11.2	Regular thorough check.....	59
<b>12</b>	<b>Technical data.....</b>	<b>60</b>
12.1	Data sheet.....	60
12.2	Response time of safety system.....	60
<b>13</b>	<b>Ordering information.....</b>	<b>62</b>
13.1	Ordering information and scope of delivery.....	62
13.2	Ordering information.....	62
<b>14</b>	<b>Accessories.....</b>	<b>63</b>
14.1	Connectivity.....	63
14.2	Emergency stop and reset pushbutton.....	64
<b>15</b>	<b>Spare parts.....</b>	<b>65</b>
15.1	sBot Speed CIP spare parts.....	65
<b>16</b>	<b>Annex.....</b>	<b>66</b>
16.1	Checklists.....	66
16.1.1	Checklist for initial commissioning and commissioning.....	66

## 1 About this document

### 1.1 Purpose of this document

These operating instructions contain the information required during the life cycle of the safety system. This document describes:

- The individual components
- The project planning
- The mounting and electrical installation, insofar as special measures are necessary for the safety system
- The configuration
- The necessary thorough checks
- The commissioning
- The maintenance
- The troubleshooting

### 1.2 Scope

These operating instructions contain information regarding the sBot Speed CIP – FA safety system.



#### NOTICE

The operating instructions of the components also apply.

The relevant information must be made available to the employees for all work performed on the safety system.

The following documents contain additional information:

Table 1: Documents available from SICK

Document type	Title	Part number
Operating instructions	microScan3 EFI-pro	8021911
Operating instructions	Flexi Soft modular safety controller hardware	8012999
Operating instructions	Flexi Soft in the Flexi Soft Designer software	8012998
Operating instructions	Flexi Soft Gateways Hardware	8012662
Operating instructions	Flexi Soft Gateways in the Safety Designer configuration software	8018170

Table 2: Robot controller documents

Document type	Title	Part number
Operator's manual	FANUC robot series R-30iB/R-30iB Mate/R-30iB Plus/R-30iB Mate Plus/R-30iB Compact Plus CONTROLLER Dual Check Safety Function	B-83184EN / 08
Operator's manual	FANUC robot series R-30iA/R-30iA Mate/R-30iB/R-30iB Mate/R-30iB Plus/R-30iB Mate Plus/R-30iB Compact Plus EtherNet/IP	B-82854EN / 03

The robot controller documents can be accessed via the FANUC download portal [my.fanuc.eu](http://my.fanuc.eu).

This document is included with the following SICK part numbers (this document in all available language versions):

8024777

### 1.3 Target groups of these operating instructions

Some chapters of these operating instructions are intended for certain target groups. However, the entire operating instructions are relevant for intended use of the product.

Table 3: Target groups and selected chapters of these operating instructions

Target group	Chapters of these operating instructions
Project developers (planners, developers, designers)	"Project planning", page 17 "Configuration", page 42 "Technical data", page 60
Installers	"Mounting", page 38
Electricians	"Electrical installation", page 39
Safety experts (such as CE authorized representatives, compliance officers, people who test and approve the application)	"Project planning", page 17 "Configuration", page 42 "Commissioning", page 49 "Technical data", page 60 "Checklists", page 66
Operators	"Operation", page 59 "Troubleshooting", page 58
Maintenance personnel	"Maintenance", page 57 "Troubleshooting", page 58

### 1.4 Symbols and document conventions

The following symbols and conventions are used in this document:

#### Safety notes and other notes



#### **DANGER**

Indicates a situation presenting imminent danger, which will lead to death or serious injuries if not prevented.



#### **WARNING**

Indicates a situation presenting possible danger, which may lead to death or serious injuries if not prevented.



#### **CAUTION**

Indicates a situation presenting possible danger, which may lead to moderate or minor injuries if not prevented.



#### **NOTICE**

Indicates a situation presenting possible danger, which may lead to property damage if not prevented.



#### **NOTE**

Indicates useful tips and recommendations.

## Instructions to action

- ▶ The arrow denotes instructions to action.
- 1. The sequence of instructions for action is numbered.
- 2. Follow the order in which the numbered instructions are given.
- ✓ The check mark denotes the result of an instruction.

## LED symbols

These symbols indicate the status of an LED:

- The LED is off.
- ◐ The LED is flashing.
- The LED is illuminated continuously.

## 1.5 Terminology used

Term	Explanation
Safety System	Combination of safety controller, safety sensors and logic.
Complete system	Combination of safety system, process controller, machine and all other actuators, sensors and switching elements that interact in the application.
Safety controller	Controller for safety applications which logically evaluates signals from safety sensors, safety command devices and other sources and securely switches the actuators of the machine on and off via safety outputs.
Robot controller	Programmable controller that controls and monitors the actions of the robot.

## 1.6 Further information

[www.sick.com](http://www.sick.com)

The following information is available via the Internet:

- Operating instructions and mounting instructions of SICK components suitable for the safety system
- Safety Designer configuration software
- Guide for Safe Machinery (“Six steps to a safe machine”)

## 2 Safety information

### 2.1 General safety note

The information and tools will not fulfill the safety requirements for your application without further adjustments being made. The project planning provided by way of example is intended to serve as the basis to allow you to perform your own project planning and programming in line with your specific requirements. What this means is that the information and tools merely provide an example to demonstrate how a safety function can be taken care of.

When it comes to your own project planning and programming, you will need to rely on qualified staff given that it is your responsibility to ensure that the following requirements are complied with at the very least:

- ▶ Carrying out a risk assessment
- ▶ Taking into account applicable standards
- ▶ Verifying and validating the safety functions.

### 2.2 Intended use

The safety system provides protection against mechanical hazards (crushing, shearing, impact) caused by movement of the robot arm by means of area safeguarding. The safety system can only be used in certain applications (see "[Requirements for the application](#)", page 12).

The safety system must only be used within the limits of the prescribed and specified technical data and operating conditions at all times.

Incorrect use, improper modification or manipulation of the safety system will invalidate any warranty from SICK; in addition, any responsibility and liability of SICK for damage and secondary damage caused by this is excluded.

### 2.3 Inappropriate use

The safety laser scanner works as an indirect protective measure and cannot provide protection from pieces thrown from application nor from emitted radiation. Transparent objects are not detected.

If necessary, you must take additional measures to provide protection against hazards that do not result from movement of the robot arm.

The safety system is not suitable for the following applications (this list is not exhaustive):

- Outdoors
- Underwater
- In explosion-hazardous areas

### 2.4 Requirements for the qualification of personnel

The safety system must be configured, installed, connected, commissioned, and serviced by qualified safety personnel only.

#### Integration

For integration, a person is considered qualified when he/she has expertise and experience in the selection and use of protective devices on machines and is familiar with the relevant technical rules and national work safety regulations.

### 2.5 Safe state of the safety outputs

If the safety outputs via the network are logic 0, this leads to robot downtime.

The safe state of the safety outputs is initiated in the following cases:

- PF2 protective field interruption
- Invalid sequence of the protective field interruption for automated restart
- Emergency stop pushbutton actuated

The following errors are recognized and also lead to the safety outputs via the network being logic 0:

- Internal error at the safety controller or one of its components
- Internal error on the safety laser scanner
- Connection between the safety controller and safety laser scanner interrupted
- Voltage supply of the safety controller or the safety laser scanner interrupted

### 3 Product description

#### 3.1 Design of the overall system

##### Design of the overall system

The overall system comprises a total of three components:

- Safety system (from SICK)
- Robot
- Safety command devices

The safety system ends at all inputs and outputs that are not used to wire the components of the safety system.

The safety-related machine controller parts (SRP/CS) are distributed among the safety system and robot controller.

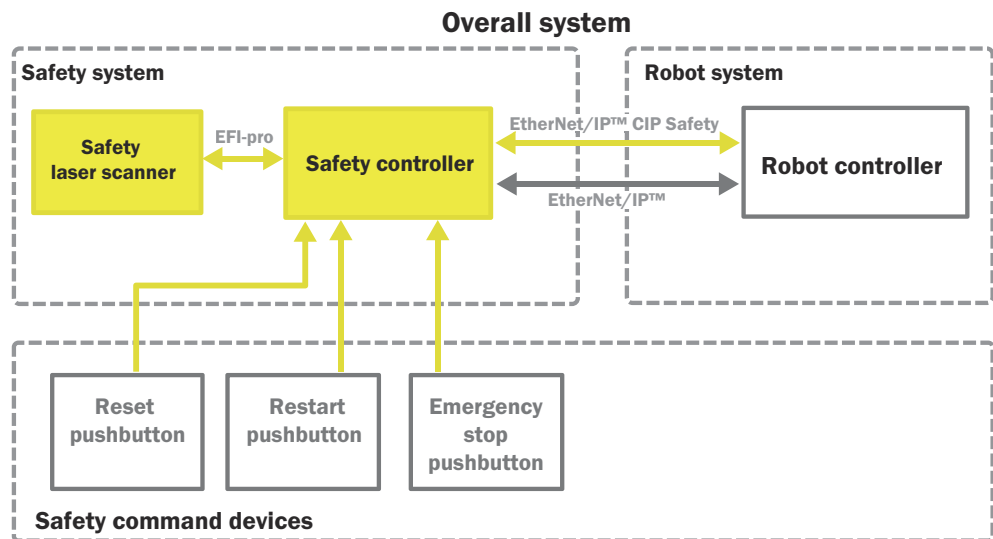

Figure 1: Construction of the entire system

##### Further topics

- ["Components", page 12](#)
- ["Interfaces", page 31](#)

#### 3.2 Functionality

##### Overview

The safety system detects people in a monitored area. When a person approaches the robot, the safety system decreases the robot speed until it comes to a standstill.

##### Functionality

The safety laser scanner monitors the access area of the hazardous area with several protective fields. When a person approaches the robot, the protective fields are interrupted one after another.

The robot speed is reduced if the first protective field is interrupted. If the second protective field is interrupted, the safety system triggers a protective stop.

If the person moves away from the robot, the protective fields become free again one after another. Restarting the robot is possible when all of the protective fields are free. The safety system monitors the sequence in which each protective field is interrupted and becomes free again. A valid sequence leads to an automated restart.

#### Complementary information

If a person approaches and then moves away from the robot, the protective fields must be interrupted and become free again in a specific sequence (safe sequence monitoring). In the event of a sequence error, it cannot be ensured that the person has left again. The safety system will switch to the safe state in this event. Automated robot restart is prevented.

#### Further topics

- ["Functions of the safety system", page 13](#)
- ["Automated restart", page 14](#)

### 3.3 Requirements for the application

- The robot controller must be a FANUC type R-30iB Plus and support the following options:
  - Ethernet I/O Scan
  - Dual Check Safety Position and Speed Check
  - Dual Check Safety Safe I/O connect
  - EtherNet/IP Safety
- Robots and humans perform their work in the same workspace, but at different times (cooperation, [see "Human-robot interaction", page 13](#)).
- The robot works at a fixed position.
- Access to the hazardous area must be designed so that the protective fields of the safety laser scanner cover the entire access area of the hazardous area. A person cannot enter or reach into the hazardous area without interrupting the protective fields.
- Bypassing the protective field (e.g. by reaching around or stepping over it) is not possible and this is ensured by additional measures as necessary.
- The area to be monitored is free from all airborne particles or process residues in its operational status.

### 3.4 Product characteristics

#### 3.4.1 Components

##### Components relevant for the safety system

Table 4: Hardware

Component	Part of the safety system?	Included in scope of delivery
Flexi Soft safety controller <ul style="list-style-type: none"> <li>• FX3-CPU0 main module</li> <li>• Gateway FX3-GEPRO</li> <li>• Expansion module FX3-XTIO</li> <li>• FX3-MPLO system plug</li> </ul>	Yes	Yes
microScan3 Core EFI-pro safety laser scanner	Yes	Yes
Emergency stop pushbutton	No	No
Reset pushbutton	No	No
Pushbutton for restart	No	No
Robot controller type R-30iB Plus	No <sup>1)</sup>	No

<sup>1)</sup> The robot controller is not part of the SICK safety system. Safety-relevant functions for the entire system are however executed in the robot controller.

Table 5: Software

Name	Availability
Pre-configured project file for Safety Designer with the following components: <ul style="list-style-type: none"> <li>• Logic for safety controller</li> <li>• Configuration file of the safety laser scanner</li> <li>• Settings for network communication</li> </ul>	SICK provides you with a ZIP archive when you purchase the safety system.
Complete subsystems for SISTEMA	
Circuit diagram (ePLAN)	

Implementing all the safety functions for the application requires a complete system consisting of sensors, a controller, actuators, and control switches. This safety system comprises sensors and a controller only and is therefore only a subsystem. The user is responsible for the safe design of the complete system and all safety functions.



**NOTE**

All necessary components influence the parameters of the entire application that relate to safety technology. The components must therefore have an MTTFd value that is suitable for the entire application and satisfies the necessary performance level. The necessary performance level results from the risk assessment. Subsystems for SISTEMA are available for evaluation of the achieved performance level under:

[www.sick.com](http://www.sick.com)

**Further topics**

- "Emergency stop pushbutton requirements", page 30
- "Requirements for the reset pushbutton and restart button", page 31

**3.4.2 Human-robot interaction**

This safety system is suitable for cooperative human-robot interaction.

Table 6: Types of human-robot interaction

	Application with sequential processing	Application with simultaneous processing
Shared workspace	Cooperation	Collaboration
Different workspace	(Not interactive)	Coexistence

Cooperative human-robot interaction is characterized by the fact that tasks are being carried out in the same working area at different times.

**3.4.3 Functions of the safety system**

Function	Trigger	Description
Emergency stop	Emergency stop pushbutton actuated	Activates the emergency stop function and triggers the robot stop. Corresponds to stop category 1. After resetting the emergency stop pushbutton and the safety system, the robot accepts a manual restart. Expected frequency of safety function request: 12 times per year

Function	Trigger	Description
Prevent unexpected restarting after an emergency stop	Reset pushbutton and restart button actuated	Restarting the robot is also prevented after resetting the emergency stop pushbutton. The operator must manually reset the safety system and start the robot manually.
Trigger safety-rated monitored speed	Protective field PF1 interrupted	Activates robot speed decrease. Activates the safe monitoring of the robot speed with a certain time delay.
Initiate a protective stop	Protective field PF2 interrupted	Triggers the robot protective stop. Corresponds to stop category 2.
Manual reset and manual restart	Protective field PF3 interrupted or error in sequence monitoring for automated restart	Only possible when the safety system is in a safe state and all protective fields are free. Leads to robot restart. Expected frequency of safety function request: 365 times per year (once daily)
Automated reset and restart with safe sequence monitoring	see " <a href="#">Automated restart</a> ", page 14 In the event of an error in the sequence monitoring: Manual reset and manual restart	

#### 3.4.4 Automated restart

##### Important information



##### NOTE

The automated restart fulfills the requirements of ISO 10218.

##### Sequence for automated restart

Automated restart of the robot only occurs when one or several people approach and then move away from the robot so that only protective fields PF1 and PF2 are interrupted in doing so.

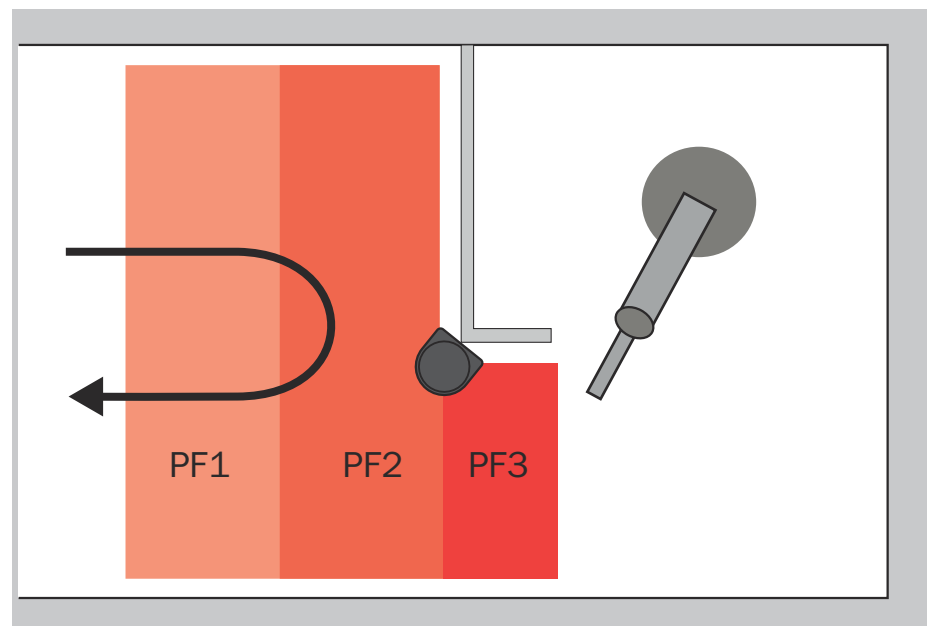

Figure 2: Movement path of a person for automated restart

In doing so, the protective fields are interrupted in a certain sequence and then approved again. This sequence is expected by the logic of the safety controller and corresponds to the following signal image.

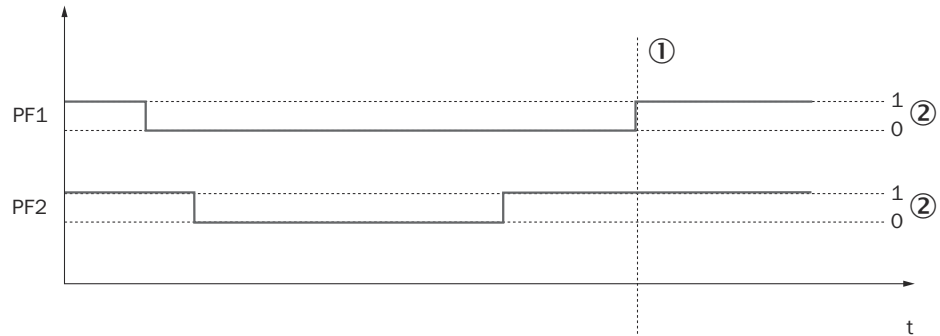

Figure 3: Signal image of a valid sequence for automated restart

- ① Automated restart is triggered.
- ② Signal states of the safety laser scanner’s safety outputs via the network.
  - Protective field free: signal state = logical 1
  - Protective field interrupted: signal state = logical 0

**Complementary information**

If the sequence is not complied with after protective field PF2 is interrupted, the safety outputs of the safety system switch to a safe state. Automated restart is prevented and manually resetting with manual restart is required. The sequence is invalid when, for example:

- The protective field PF1 becomes free at the same time as protective field PF2 (discrepancy PF1 / PF2).
- Protective field PF2 is interrupted without protective field PF1 having been interrupted prior to this.

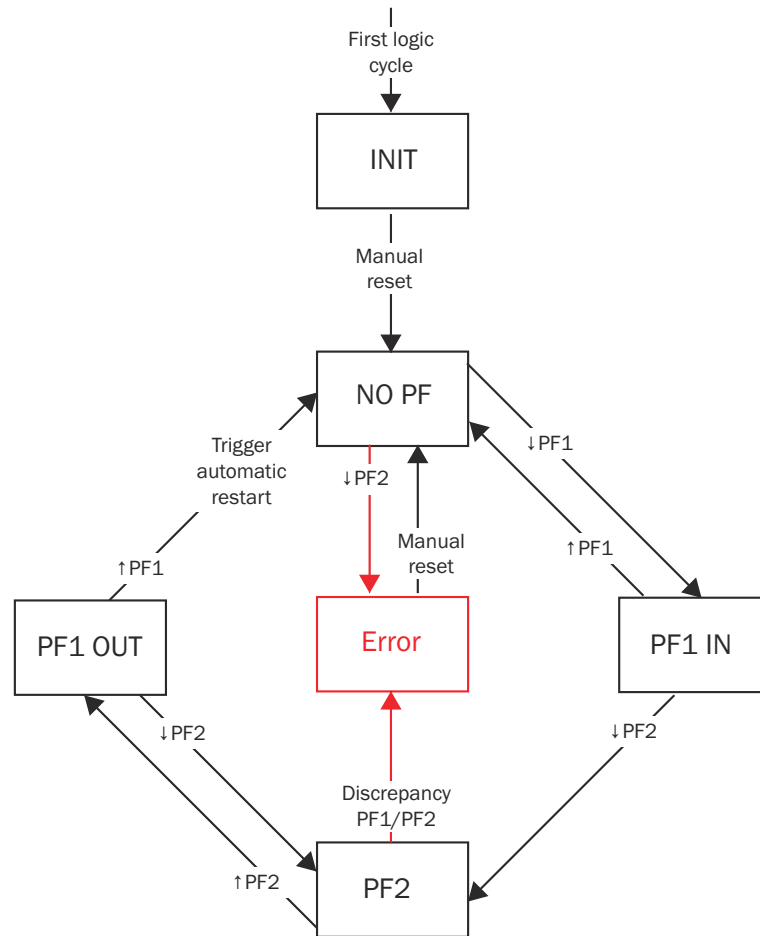

Figure 4: Block diagram for sequence monitoring

↓	Protective field is interrupted.
↑	Protective field becomes free.
INIT	Status after the first logic cycle of the safety controller
NO PF	All protective fields are free and the safety system has been reset.
PF1 IN	Protective field PF1 is interrupted. Protective field PF2 has not yet been interrupted.
PF2	Protective fields PF1 and PF2 are interrupted.
PF1 OUT	Protective field PF2 is free again, protective field PF1 is interrupted.
Error	Error status due to invalid protective field interruption sequence

## 4 Project planning

### 4.1 Manufacturer of the overall system



#### **DANGER**

Hazard due to lack of effectiveness of the protective device

The dangerous state of the overall system may not be stopped or not be stopped in a timely manner in the event of non-compliance.

- ▶ Use of the safety system requires a risk assessment. Check whether additional protective measures are required.
- ▶ Comply with the applicable national regulations derived from the application (e.g., work safety regulations, safety rules, or other relevant safety guidelines).

The safety system was developed under consideration of typical application cases. A partial safety function can be implemented with the safety system in these application cases. The manufacturer must check whether the safety system is suitable for its specific application case (risk assessment).

If the thorough check shows that the safety system is not suitable for the specific application case, the safety system can be used as a basis for an individualized development suitable for the specific application case. This case will not be considered further in this document.

In any event, additional work is necessary for the safety system to be used, e.g. subsequent configuration of the safety controller.

The manufacturer has the following duties:

- ▶ Executing a risk assessment.
- ▶ Verifying and validating the safety functions.
- ▶ Integrating the individual components in accordance with the appropriate standards.
- ▶ Please note that C standards have priority compared to statements about this safety system.

#### 4.1.1 Reasonably foreseeable misuse

The manufacturer must take into account the reasonably foreseeable misuse, among other things, in the risk analysis. The following reasonably foreseeable misuse scenarios have been identified during development of this safety system:

##### **Misuse by the manufacturer**

- The application has hazards that cannot be protected against by an electro-sensitive optical protective device.
- The safety laser scanner works as an indirect protective measure and cannot provide protection from pieces thrown from application nor from emitted radiation. Transparent objects are not detected.
- Incorrect design of the field sets, e.g. protective fields are designed to be too small.

##### **Misuse by the user/employee**

- The user may not bring any stools, seats, ladders, or other objects into the monitored area with which the user can climb over the scanning field into the hazardous area.
- Transparent objects are not detected.

## 4.2 Operating entity of the overall system



### DANGER

Hazard due to lack of effectiveness of the protective device

The dangerous state of the overall system may not be stopped or not be stopped in a timely manner in the event of non-compliance.

- ▶ Changes to the electrical integration of the safety system in the machine control and changes to the mechanical mounting of the safety system necessitate a new risk assessment. The results of this risk assessment may require the entity operating the machine to meet the obligations of a manufacturer.
- ▶ Changes to the safety system's configuration may impair the protective function. The effectiveness of the safety system must be checked after any change to the configuration. The person carrying out the change is also responsible for maintaining the protective function of the safety system.

## 4.3 Design

### 4.3.1 Design of the access point to the hazardous area (example)

The access point to the hazardous area is monitored with several protective fields. The protective fields are interrupted in sequence when the hazardous area is approached. For the configuration with 3 protective fields, the third protective field PF3 serves as presence detection immediately in front of the hazardous area.

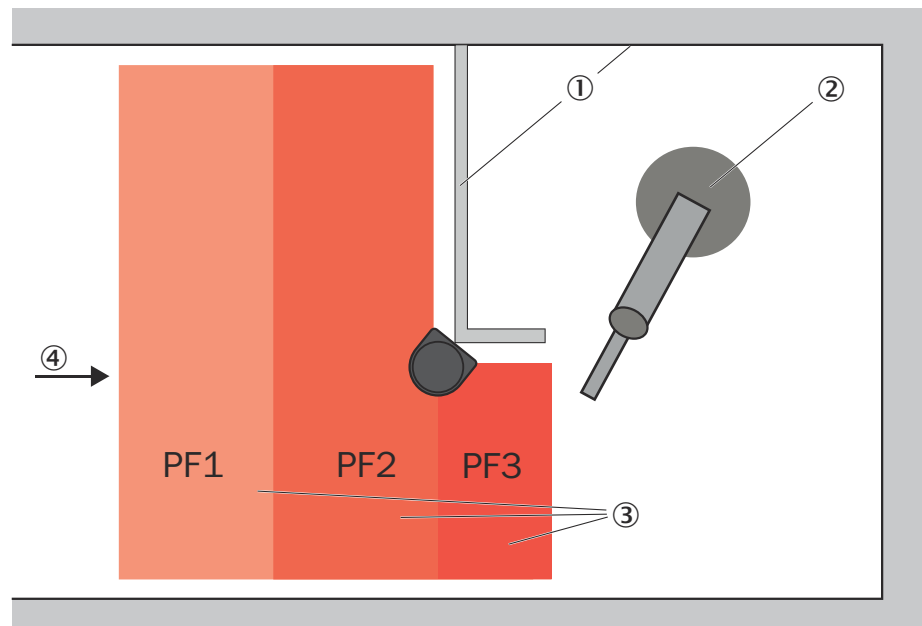

Figure 5: Ideal design of the access to the hazardous area

- ① Fixed physical guard, e.g. fencing
- ② Robots to be protected
- ③ Protective fields of the safety laser scanner
- ④ Approach direction to hazardous area

### 4.3.2 Position of the safety laser scanner

#### Requirements for the position of the safety laser scanner

Position the safety laser scanner so that it meets all of the following criteria:

- The scan plane runs horizontally.
- The scan plane runs 300 mm above the floor. The risk assessment may indicate that a lower scan plane is necessary.
- The safety laser scanner must be mounted at the position at which the last configured protective field begins (for standard configuration: PF3, otherwise PF2).

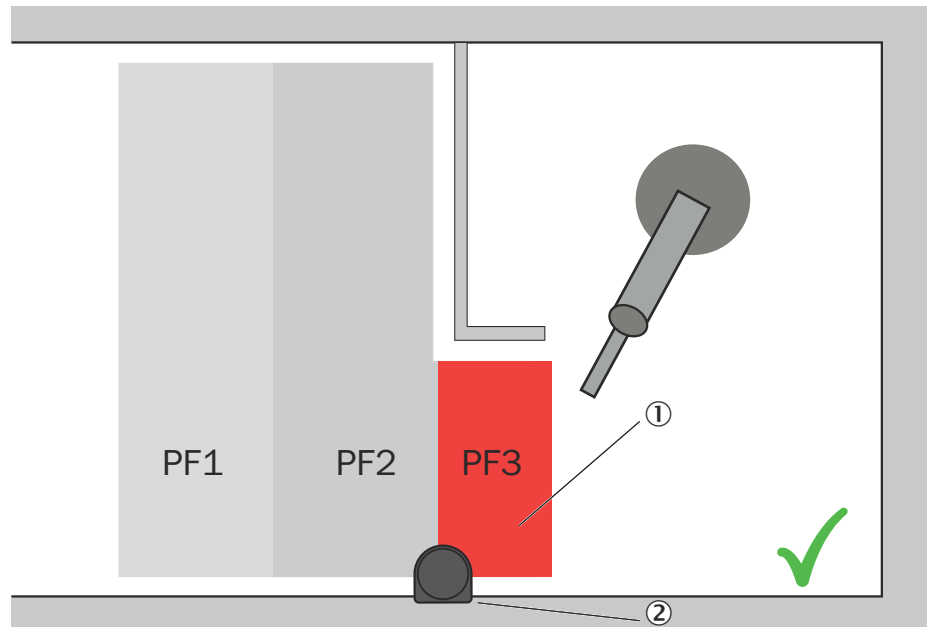

Figure 6: Safety laser scanner positioned at the correct distance to the hazardous point

- ① Protective field PF3 can be configured correctly.
- ② Safety laser scanner

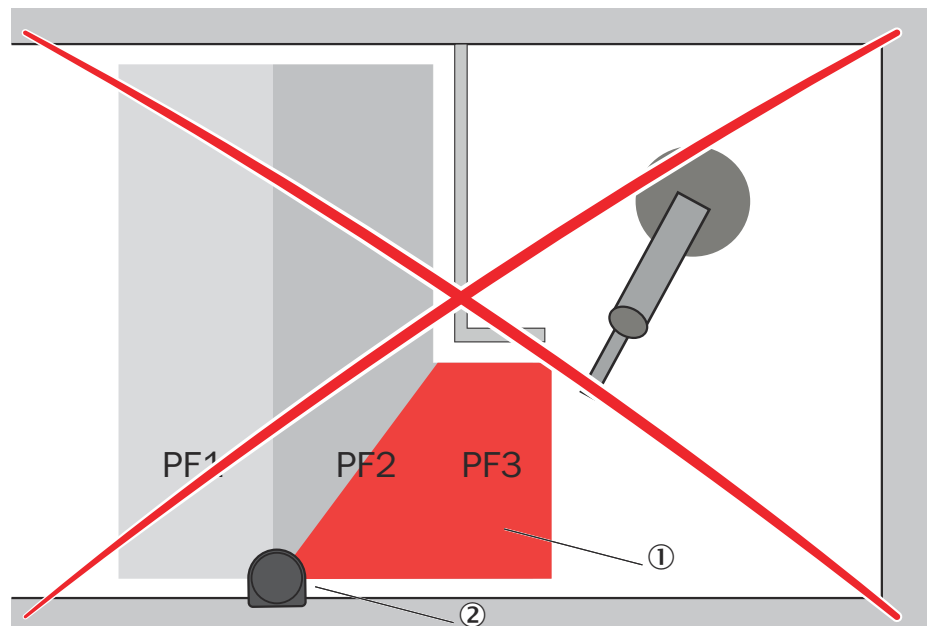

Figure 7: Safety laser scanner placed with too great a distance to the hazardous point

- ① Protective field PF3 cannot be configured according to the requirements of the safety system.
- ② Safety laser scanner

- The safety laser scanner can monitor the entire access area to the hazardous area. There are no areas that are not monitored where a person can be present (e.g. in front of a physical guard).

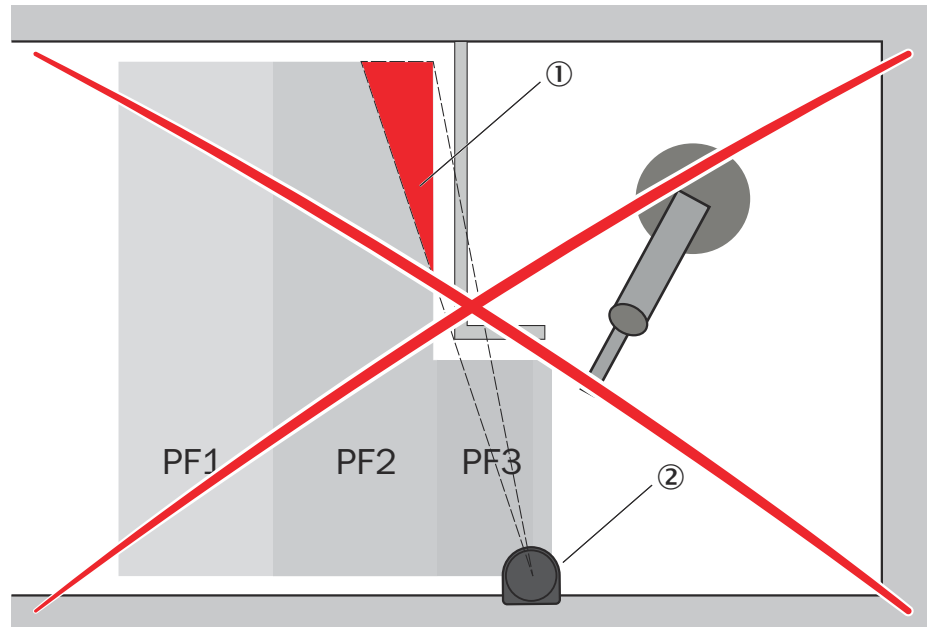

Figure 8: Non-monitored area in the shadow of the physical guard

- ① Non-monitored area
- ② Safety laser scanner

**Examples of possible positions of the safety laser scanner**

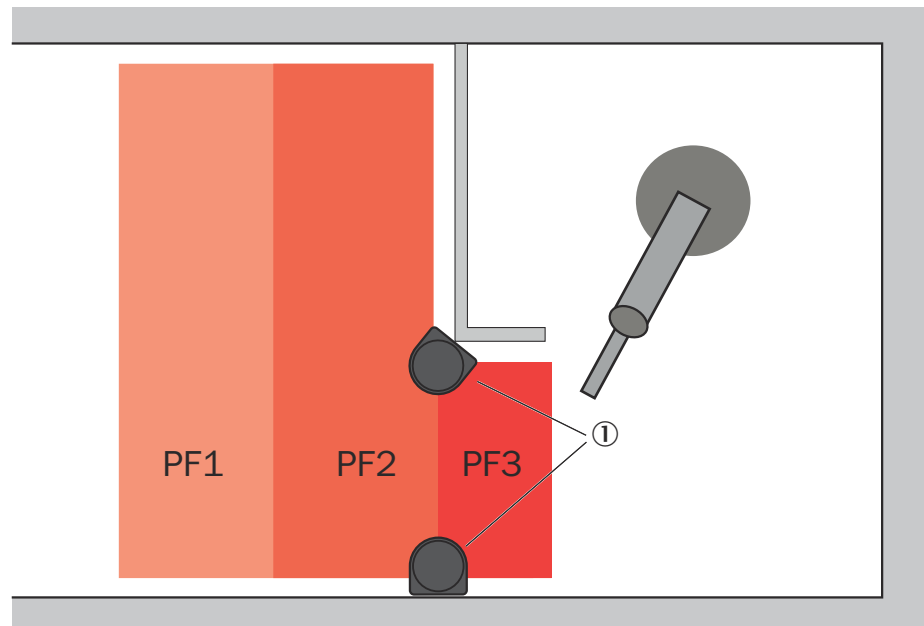

Figure 9: Possible positions of the safety laser scanner when used with a physical guard

- ① Safety laser scanner

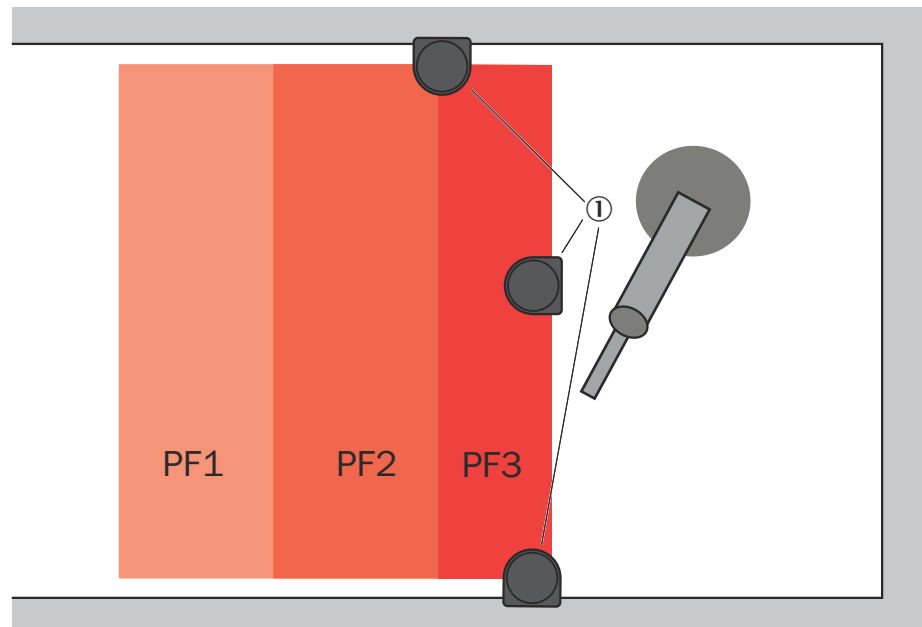

Figure 10: Possible positions of the safety laser scanner when used without a physical guard

① Safety laser scanner

### 4.3.3 Protective field design

#### 4.3.3.1 Selecting the number of protective fields

##### Overview

The safety laser scanner monitors access to the hazardous area with several protective fields. Depending on the application and the risk assessment, you can configure the safety system with 3 or 2 protective fields. The configuration with 3 protective fields is the standard configuration.

##### Important information



##### **DANGER**

For the configuration with 2 protective fields, the safety system cannot reliably detect a person standing behind the protective device in all application cases.

The robot can possibly perform an automated start-up again, even though a person is in the hazardous area.

- ▶ Only use the configuration with 2 protective fields if one of the following points can be guaranteed:
  - It is not possible to stand behind the protective device.
  - There is never more than one person in the safety laser scanner's monitored area.

**Configuration with 3 protective fields (standard)**

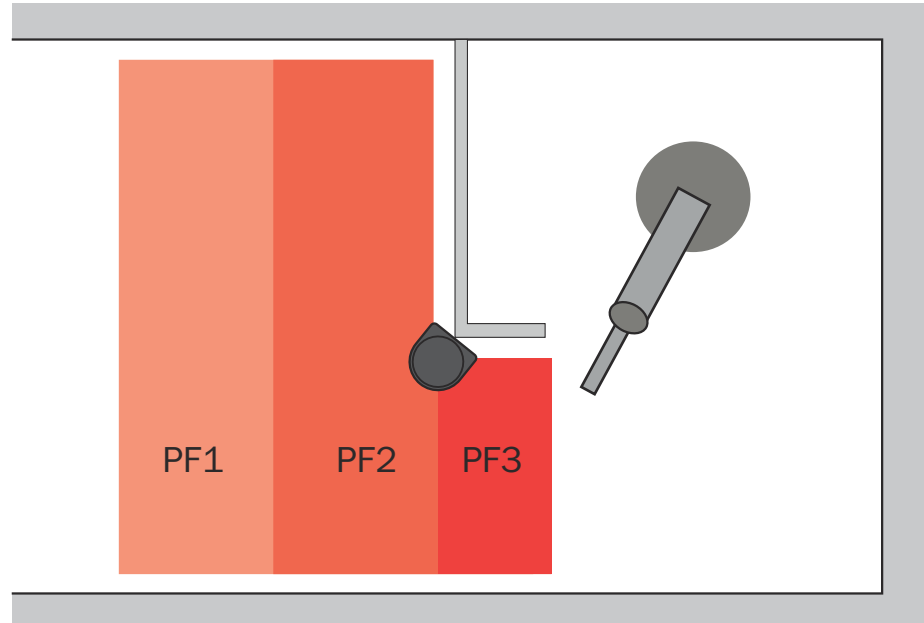

Figure 11: Configuration with 3 protective fields

The safety system evaluates the following cases as a person standing behind the protective device:

- There is an invalid protective field interruption sequence.
- The additional protective field PF3 is interrupted.

The safety system then switches to the safe state and must be manually reset.

**Configuration with 2 protective fields**

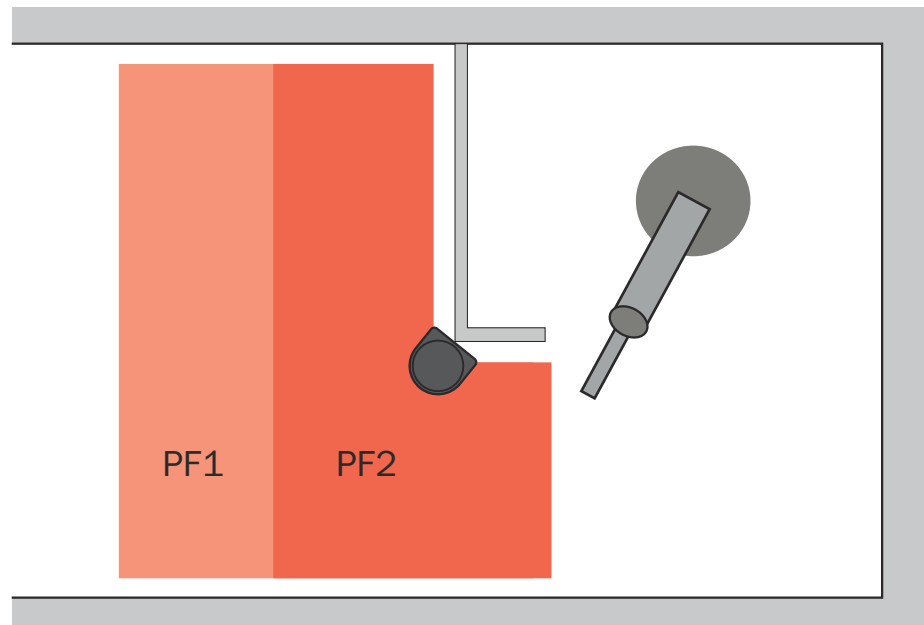

Figure 12: Configuration with 2 protective fields

The safety system evaluates the following cases as a person standing behind the protective device:

- There is an invalid protective field interruption sequence.

The safety system then switches to the safe state and must be manually reset.

#### Complementary information

The configuration with 2 protective fields is not suitable for every application case for the following reason:

If 2 or more people are in the monitored area, someone standing behind the protective device does not always trigger an invalid sequence.

Example: One person is in protective field PF1. A second person approaches, passes through all protective fields, and steps into the hazardous area behind the protective device. The second person is no longer detected by the safety laser scanner. When the first person leaves again, protective field PF1 becomes free. This corresponds to a valid sequence for an automated restart, even though a person is in the hazardous area.

#### Further topics

- ["Automated restart", page 14](#)

#### 4.3.3.2 Overlapping protective fields

The safety laser scanner simultaneously monitors several protective fields (3 protective fields in the standard configuration). These protective fields partially overlap.

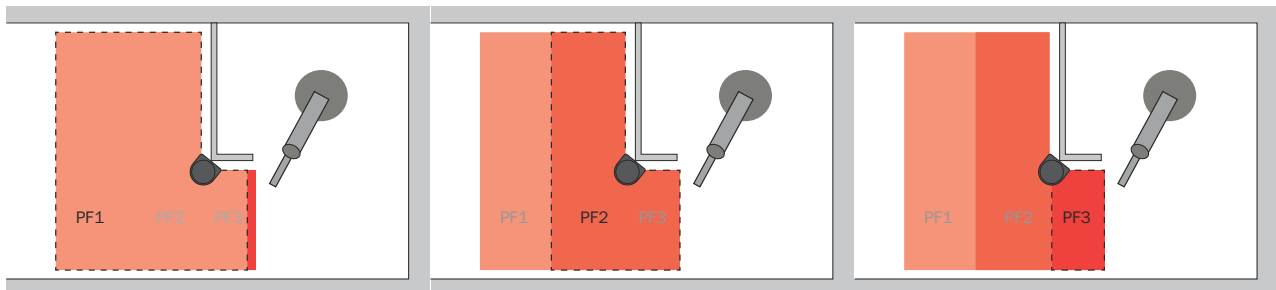

Figure 13: Position of protective field PF1 Figure 14: Position of protective field PF2 Figure 15: Position of protective field PF3

#### 4.3.3.3 Distance between the ends of protective fields PF1 and PF2

##### Overview

Using sequence monitoring, the system can differentiate between a person leaving the hazardous area or entering into the hazardous area. So that the safety system can reliably determine this in every case, the protective fields PF1 and PF2 cannot end congruently at the edge of the hazardous area. If a person enters into the hazardous area, protective field PF1 must first become free.

##### Distance between the ends of protective fields PF1 and PF2

The end of protective field PF1 must have a gap to the end of protective field PF2. The distance must correspond to at least the tolerance zone (TZ) of the safety laser scanner.

TZ of the microScan3 Core EFI-Pro safety laser scanner with protective field range of 5.5 m: 65 mm

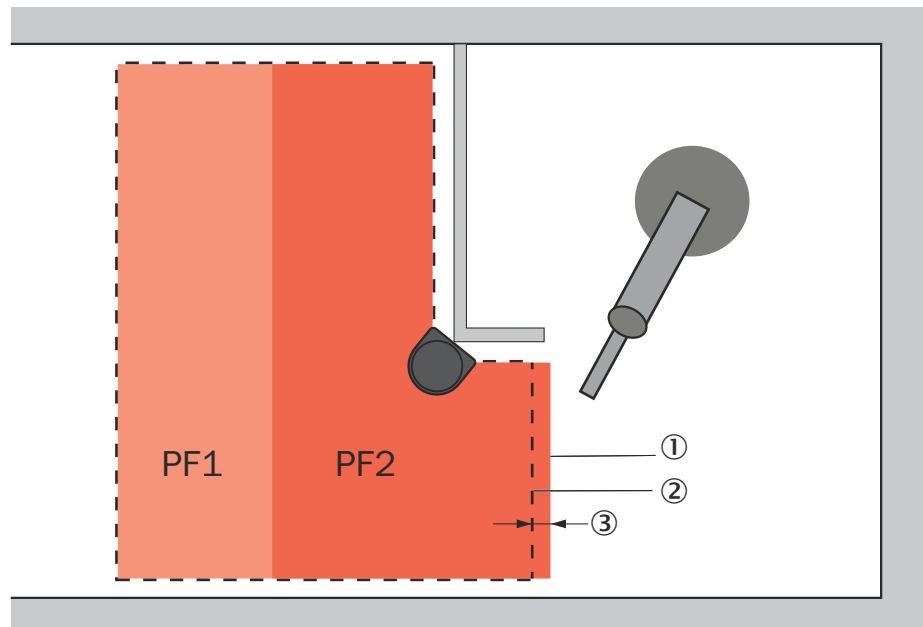

Figure 16: Distance between the ends of the protective fields

- ① End of protective field PF2
- ② End of protective field PF1
- ③ Distance between the end of protective field PF1 and end of protective field PF2

#### 4.3.3.4 Minimum distances of protective fields PF1 and PF2 to the hazardous area

You must calculate the minimum distance to the hazardous area for each protective field PF1 and PF2. When doing so, protective field PF1 depends on the size of protective field PF2. Therefore you must determine 3 dimensions.

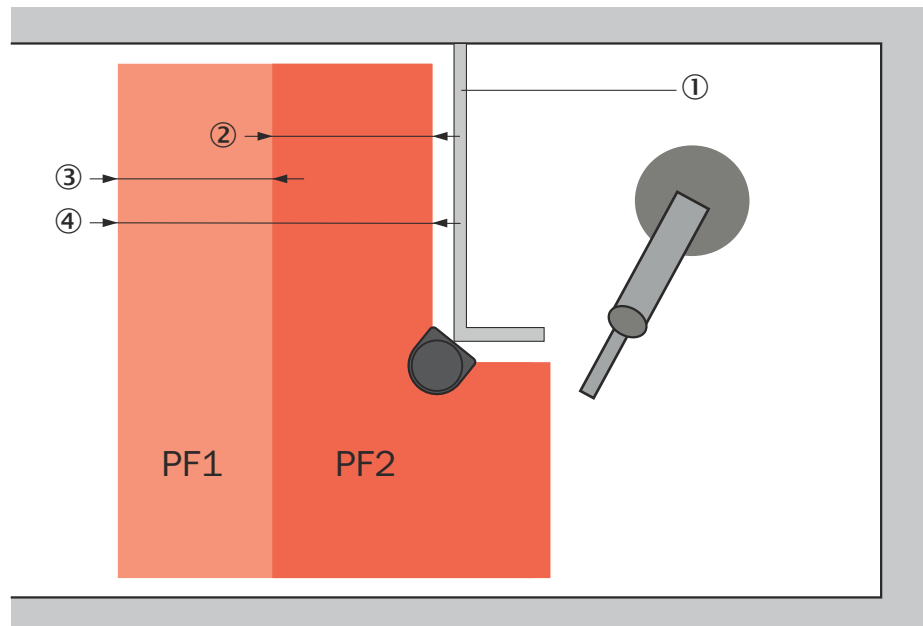

Figure 17: Different distances for physical guards that can be reached over

- ① Physical guard that can be reached over, e.g. table to place assembly item
- ② Minimum distance to the hazardous area for protective field PF2 ( $S_{PF2}$ )
- ③ Difference between the minimum distances to the hazardous area for protective fields PF1 and PF2 ( $S_{Diff}$ )
- ④ Minimum distance to the hazardous area for protective field PF1

- ④ Minimum distance to the hazardous area for protective field PF1 ( $S_{PF1}$ )

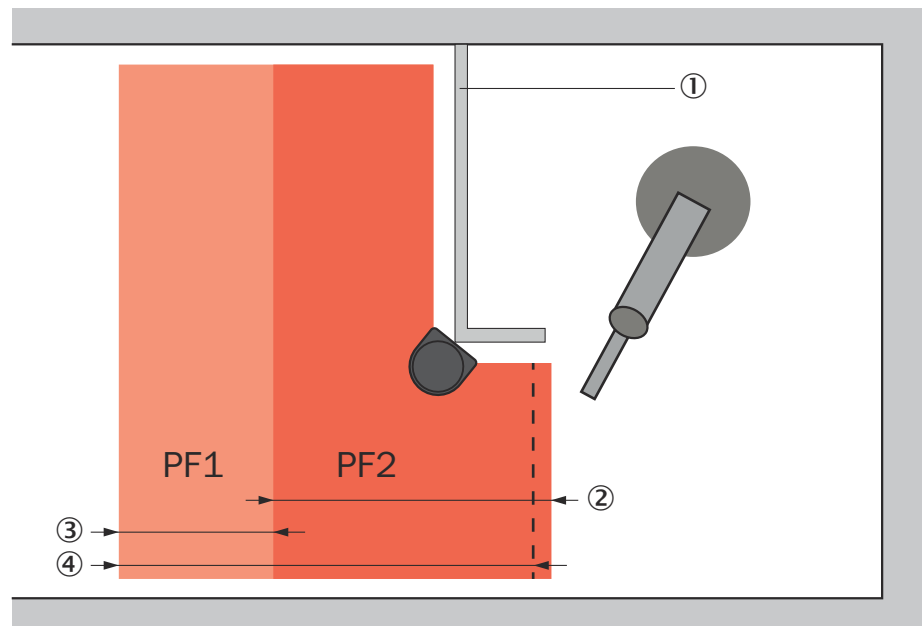

Figure 18: Different distances for physical guards that cannot be reached over

- ① Physical guards that cannot be reached over  
 ② Minimum distance to the hazardous area for protective field PF2 ( $S_{PF2}$ )  
 ③ Difference between the minimum distances to the hazardous area for protective fields PF1 and PF2 ( $S_{Diff}$ )  
 ④ Minimum distance to the hazardous area for protective field PF1 ( $S_{PF1}$ )

#### Complementary information

Many applications do not have enough space to design the protective fields according to the following calculations. This case is considered further in the following chapter: [page 29](#).

#### Further topics

- "Calculating the minimum distance to the hazardous area of the protective field PF2", page 25
- "Determining the difference between the minimum distances to the hazardous area", page 27
- "Calculating the minimum distance to the hazardous area of the protective field PF1", page 28
- "Reducing protective field PF1 in case of limited space", page 29

#### 4.3.3.4.1

#### Calculating the minimum distance to the hazardous area of the protective field PF2

##### Overview

Interrupting the protective field PF2 triggers a robot protective stop. You must calculate the minimum distance of protective field PF2 so that the robot comes to a standstill in the event of a protective field interruption before the person reaches the hazardous area.

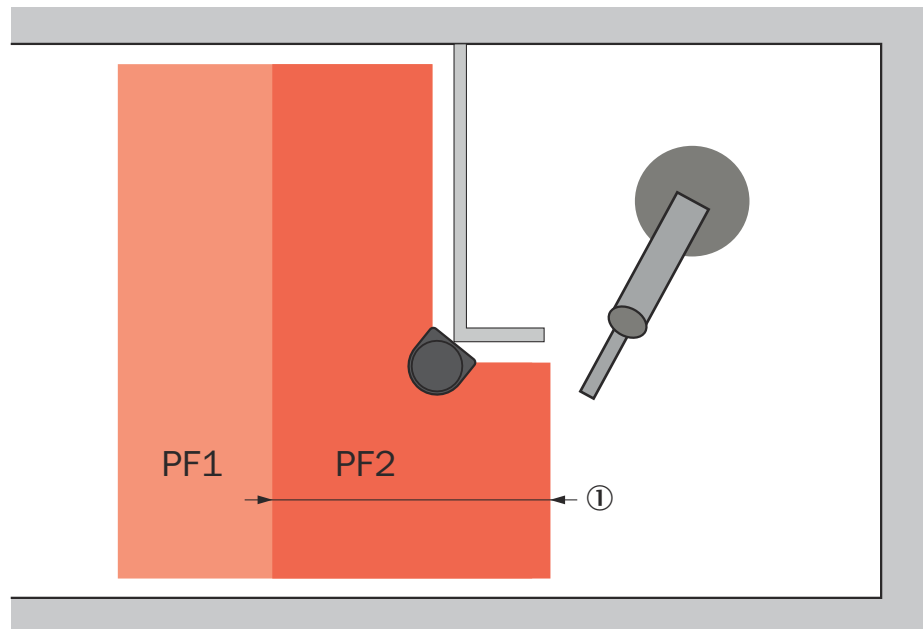

Figure 19: Minimum distance of the protective field PF2

① Minimum distance to the hazardous area for protective field PF2 ( $S_{PF2}$ )

**Approach**

1. Calculate the minimum distance to the hazardous area for protective field PF2 according to ISO 13855.

$$S_{PF2} = K \times (t_{\text{Safety system}} + t_{\text{Delay}} + t_{\text{Robot}}) + TZ + Z_R + C$$

Parameter	Description
K	Approach speed of a person. The approach speed is 1,600 mm/s according to EN ISO 10218-2.
$t_{\text{Safety system}}$	Response time of safety system
$t_{\text{Delay}}$	Delay time for activating the safety stop on the robotics (in seconds).
$t_{\text{Robot}}$	Response time of the robot when an error arises during standstill monitoring (e.g., standstill not reached after the delay time). Since the safety-rated monitored speed is activated at the time when the protective field is interrupted, you can take the corresponding speed limit into account when selecting the response time.
TZ	Tolerance range of the safety laser scanner 65 mm <sup>1)</sup>
$Z_R$	supplement for reflection-based measurement errors in millimeters (mm) All devices: If there is a retroreflector in the vicinity of the protective device (distance of the retroreflector from protective field $\leq 6$ m), you must take the supplement $Z_R = 350$ mm into account.
C	Supplement to protect against reaching over in millimeters (mm) $C = 1,200 \text{ mm} - (0.4 \times \text{protective field height (mm)})$ At a protective field height of 300 mm: 1,080 mm

<sup>1)</sup> Applies to the safety laser scanners included in the scope of delivery of the safety system.

**Further topics**

- ["Minimum distances of protective fields PF1 and PF2 to the hazardous area", page 24](#)
- ["Response time of safety system", page 60](#)

**4.3.3.4.2****Determining the difference between the minimum distances to the hazardous area****Overview**

The sequence for automated restart requires that protective field PF1 is interrupted before protective field PF2 when the hazardous area is approached. The minimum distance to the hazardous area must therefore be greater for protective field PF1 than for protective field PF2.

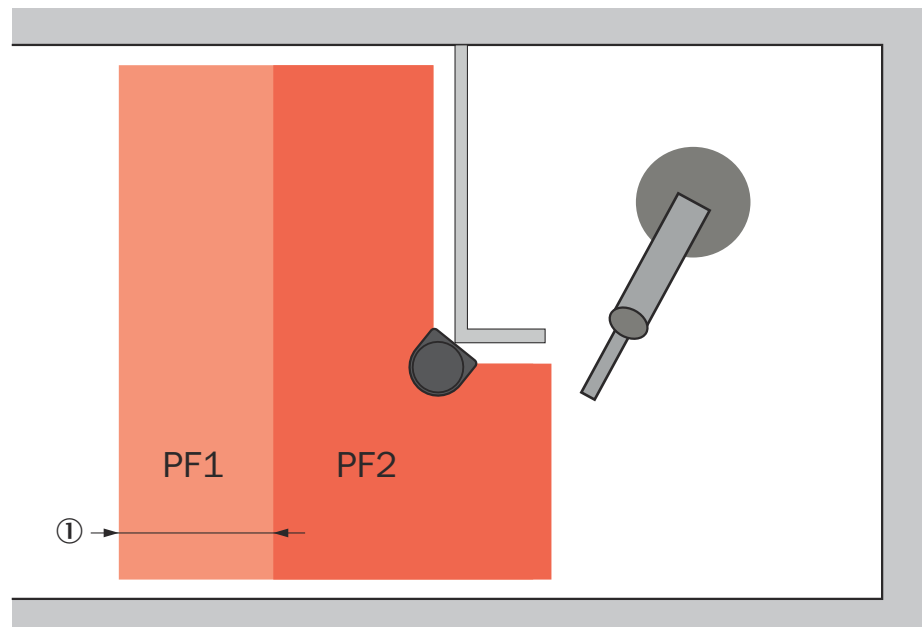

Figure 20: Difference between the minimum distances to the hazardous area

- ① Difference between the minimum distances to the hazardous area between protective fields PF1 and PF2 ( $S_{Diff}$ )

This difference is required for the following reasons:

- Sequence for automated restart
- Time window for activating the safety-rated monitored speed on the robot

**Approach**

1. Calculate  $S_{Diff}$  using the following formula:

$$S_{Diff} = K \times (t_{SafetySystem} + t_{Delay}) + TZ + Z_R$$

Formula symbols	Description
$S_{Diff}$	Difference between the minimum distances of protective fields PF1 and PF2 to the hazardous area (mm)
K	Approach speed of a person 1,600 mm/s (EN ISO 10218-2)
$t_{Delay}$	Delay time for activating safety-rated monitored speed on the robot (in seconds). <a href="#">see "Robot safety signals page", page 47</a>
$t_{SafetySystem}$	Response time of safety system (in seconds)

Formula symbols	Description
TZ	Tolerance range of the safety laser scanner 65 mm <sup>1</sup>
Z <sub>R</sub>	Supplement for reflection-based measurement errors in millimeters (mm) All devices: If there is a retroreflector in the vicinity of the protective device (distance of the retroreflector from protective field ≤ 6 m), you must take the supplement Z <sub>R</sub> = 350 mm into account.

<sup>1</sup> Applies to the safety laser scanners included in the scope of delivery of the safety system.

**Further topics**

- ["Response time of safety system", page 60](#)

**4.3.3.4.3**

**Calculating the minimum distance to the hazardous area of the protective field PF1**

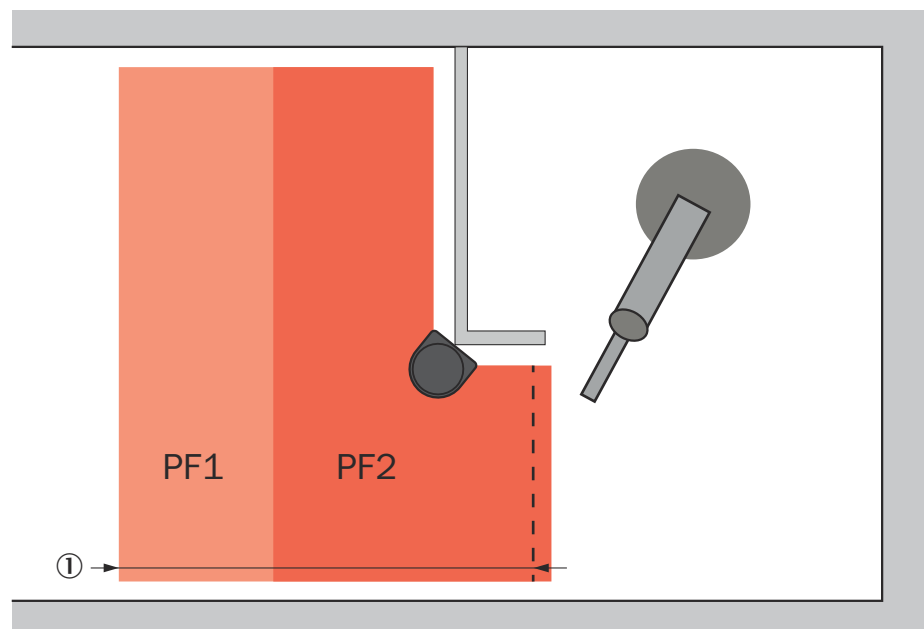

Figure 21: Minimum distance of the protective field PF1

- ① Minimum distance to the hazardous area for protective field PF1 (S<sub>PF1</sub>)

**Prerequisites**

- S<sub>PF2</sub> is calculated.
- S<sub>Diff</sub> is determined.

**Approach**

1. Calculate the minimum distance to the hazardous area with the following formula:  
S<sub>PF1</sub> = S<sub>PF2</sub> + S<sub>Diff</sub>

**Further topics**

- ["Minimum distances of protective fields PF1 and PF2 to the hazardous area", page 24](#)

#### 4.3.3.4.4 Reducing protective field PF1 in case of limited space

##### Overview

If your application does not offer enough space for protective field PF1, you can reduce the size of protective field PF1. This influences protective field PF2 and the application behavior.

##### Important information



##### NOTE

The changes described here have no effect on the safety of the robot, but do affect the availability of the robot.

##### Changes to the application and calculations

###### Changes to the application

The protective field PF1 is made smaller. This has the following effects:

- When the protective field PF2 is interrupted, it can no longer be assumed that the robot has already definitely activated the safety-rated monitored speed.
- Protective field PF2 must be designed to be larger.
- The robot stops earlier when the hazardous area is approached.

Table 7: Changes to the calculations for the minimum distances to the hazardous area

Dimension	Changes in calculating	Explanation
$S_{PF2}$	<p>Calculating the minimum distance to the hazardous area of the protective field PF2</p> <p>Take the maximum speed of the robot into account when selecting the response time of the robot. Use this time to calculate the minimum distance to the hazardous area.</p>	Safety-rated monitored speed is not definitely activated.
$S_{Diff}$	<p>Determining the difference between the minimum distances to the hazardous area</p> <p>Instead of the calculation, use the following value: 500 mm</p>	This value is a compromise between small footprint and robot availability. In extreme cases, you can reduce the value down to 160 mm. In practice, a value < 500 mm significantly impairs the availability of the robot.
$S_{PF1}$	<p>Calculating the minimum distance to the hazardous area of the protective field PF1</p> <p>No change to the formula</p>	-

##### Further topics

- [see "Minimum distances of protective fields PF1 and PF2 to the hazardous area", page 24](#)

#### 4.3.3.5 Minimum distance to the hazardous area for protective field PF3

##### Minimum distance to hazardous area

The protective field PF3 must be large enough that a person cannot step over the protective field without interrupting it when doing so. SICK recommends a minimum size of 750 mm.

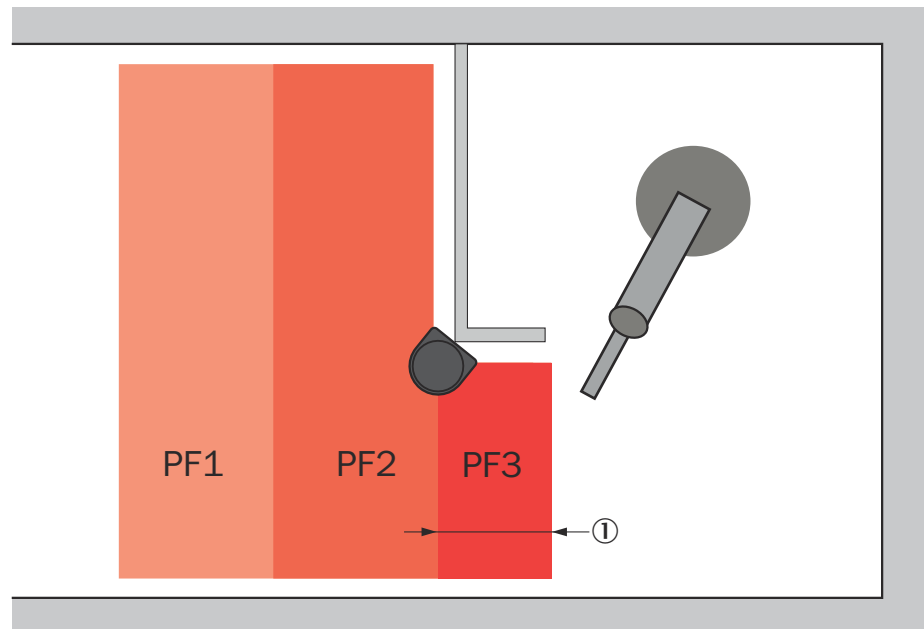

Figure 22: Minimum distance to the hazardous area for protective field PF3

① Minimum distance to the hazardous area for protective field PF3

**Complementary information**

The value of 750 mm for the minimum size of the protective field PF3 has been derived from the ISO 13855 standard. In this standard, 750 mm is the minimum width for pressure sensitive mats/plates so that they cannot be stepped over. Since the scanning field of the safety laser scanner usually runs 300 mm over the floor, stepping over it is even more difficult than with a pressure sensitive mat/plate.

**4.3.4 Robot operating modes**

Selecting between the robot operating modes is not a part of this safety system. You must carry out selection of the operating mode and the safety functions in the manual operating mode via the robot controller. You can use the operating mode selector switch and the enabling device on the robot’s operating panel, for example.

This safety system takes the following operating modes into account:

- Automated
- Manual, reduced speed (signals for protective stop and safety-rated monitored speed are bypassed).

**4.3.5 Warning signs for automated restart**

The safety system has an automated restart function. You must place a corresponding warning sign on the application.

ISO 7010, warning sign W018

**4.3.6 Emergency stop pushbutton requirements**

**Prerequisites**

- The emergency stop pushbutton must be designed according to ISO 13850 and IEC 60204.

**Requirements for the integration design**

- At least one emergency stop pushbutton must be installed.
- The emergency stop pushbutton must be mounted outside the hazardous area.

**Complementary information**

The risk assessment can reveal that more than one emergency stop pushbutton is required. Especially in the case of applications in which users can step behind the protective device, emergency stop pushbuttons are often required in the hazardous area.

**4.3.7 Requirements for the reset pushbutton and restart button****Prerequisites**

- The reset pushbutton and the restart button must be designed according to EN 60204.

**Requirements for the integration design**

- The reset pushbutton and the restart button must be installed outside of the hazardous area.
- The reset pushbutton and the restart button must be installed outside of the protective fields.
- From the position of the reset pushbutton and the restart button, there must be a complete view of the hazardous area.

**4.4 Integrating the equipment into the electrical control****NOTE**

Several safety functions are generally necessary in order to ensure a safe design for the entire application. This requires additional components that are not part of the safety system, such as switches, fuses, and contactors. The circuit diagrams contain information on wiring the safety system with additional components within an application.

**4.4.1 Circuit diagram**

A detailed circuit diagram is available as a PDF.

**4.5 Integration into the network****4.5.1 Interfaces****Overview**

The Flexi Soft safety controller is connected to the robot controller via 2 connections, which are both established via the same cable.

- Secure network: EtherNet/IP™ – CIP Safety™
- Non-secure network: EtherNet/IP™

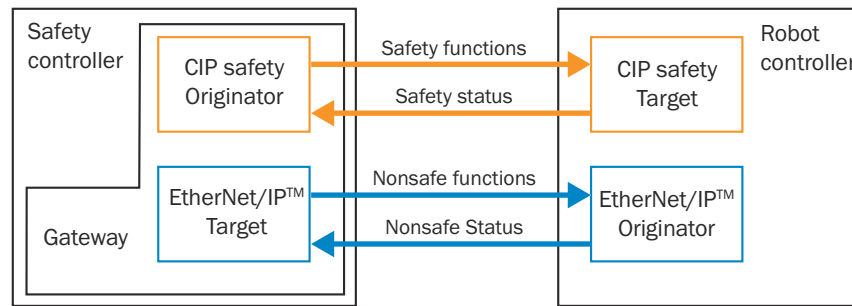

Figure 23: Network connections

**Secure network EtherNet/IP™ – CIP Safety™**

Table 8: Network structure EtherNet/IP™ – CIP Safety™

Component	IP address <sup>1</sup>	Role in the network
Flexi Soft	192.168.1.2	Originator
R-30iB Plus	192.168.1.10	Target
microScan 3 Core EFI-pro	192.168.1.3	Target

<sup>1</sup> The IP addresses in this column are the already-set example values in the pre-configured project file. You can change the IP addresses to meet your requirements.

Table 9: Assemblies used EtherNet/IP™ – CIP Safety™

Flexi Soft safety controller	Communication direction	Robot controller
161	Safety controller > robot controller	140
160	Robot controller > safety controller	130

Table 10: Output data and input data EtherNet/IP™ – CIP Safety™

Safety function	Safety controller output data	Robot controller input data
Emergency stop	161: Bit 0.0	CSI[1]
Initiate a safety stop	161: Bit 0.1	CSI[2]
Trigger safety-rated monitored speed	161: Bit 0.2	CSI[3]

**Non-secure network EtherNet/IP™**

Table 11: Network structure EtherNet/IP™

Component	IP address	Role in the network
R-30iB Plus	192.168.1.10	Originator
Flexi Soft	192.168.1.2	Target

Table 12: Assemblies used EtherNet/IP™

Flexi Soft safety controller	Communication direction	Robot controller
140	Safety controller > robot controller	Rack 89 Slot2 UI
130	Robot controller > safety controller	Rack 89 Slot2 U0

Table 13: Output data and input data EtherNet/IP™

Control signals <sup>1)</sup>	Safety controller output data	Safety controller input data			
		UI	Rack	Slot	Start
IMST	140: Bit 0.0	1	89	2	1

Control signals <sup>1)</sup>	Safety controller output data	Safety controller input data			
		UI	Rack	Slot	Start
HOLD	140: Bit 0.1	2	89	2	2
SFSPD	-	3	35	1	1
CSTOPI	140: Bit 0.3	4	89	2	4
RESET <sup>2)</sup>	140: Bit 0.4	5	89	2	5
START	140: Bit 0.5	6	89	2	6
Not used	-	7			
ENBL	140: Bit 0.7	8	89	2	8

- 1) These are non-secure control signals that must be configured so that the robot can start operation, e.g. for starting the program.
- 2) Acknowledging an error message using RESET on the robot controller does not reset the safety function in the safety controller.

## 4.6 Configuration of the robot controller

### Important information



#### NOTE

- Only authorized personnel are allowed to perform configuration of the robot controller.
- Changing safety-relevant parameters requires confirming via the **APPLY** button, confirming the report, and then restarting the robot controller.

### Configuration

The table below describes the internal routing of the safety signals on the robot safety functions.

Table 14: MENU > SYSTEM > DCS > Safe I/O connect

Output	input	Function
SSO[3] <sup>1)</sup>	CSI[1]	Emergency stop
SIR[1] <sup>2)</sup>	CSI[2] OR SSI[8] <sup>3)</sup>	Protective stop
SIR[2] <sup>4)</sup>	CSI[3] OR SSI[8] <sup>3)</sup>	Safety-rated monitored speed

- 1) SSO = Internal robot controller safety output
- 2) SIR = Internal robot controller safety relay  
Cartesian speed check with limit (value)= 0 mm/s
- 3) CSI = Secure bus input data  
SSI = Internal robot controller safety capable input  
With this configuration you bypass the safety signals of the safety controller (CSI) for the protective stop and the safety-rated monitored speed. This muting is necessary so that the robot can move in the manual operating mode.
- 4) SIR = Internal robot controller safety relay  
Cartesian speed check with configurable limit (value)

Example:

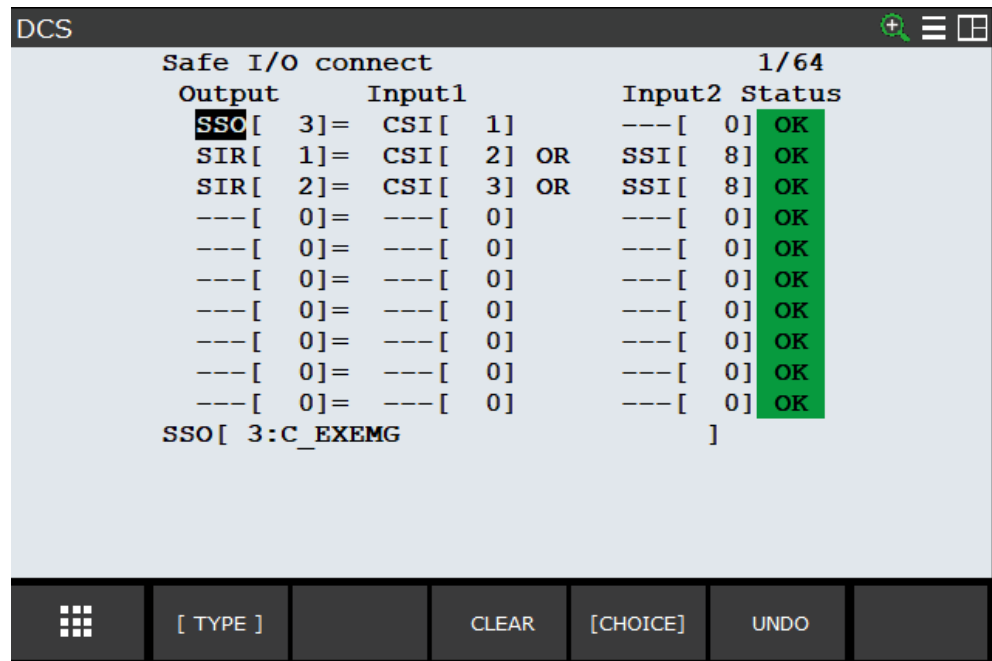

Table 15: Dual check safety > Cartesian speed check no. 1[VRED]

Field	Value
1 Enable/Disable	Enable
2 Direction:	ALL
7 Limit:	400 <sup>1) 3)</sup>
9 Speed control:	OVERRIDE
10 Override limit:	10% <sup>1)</sup>
11 Delay time:	1,000 msec <sup>1) 2)</sup>
12 Disabling input:	SIR[2]

- 1) Example value. The value must be defined by the machine manufacturer and/or integrator.
- 2) The value is relevant for calculating the minimum distance of the protective fields to the hazardous area.
- 3) If the speed exceeds the limit defined, the robot independently changes to the safe state and displays a corresponding error message.

Example:

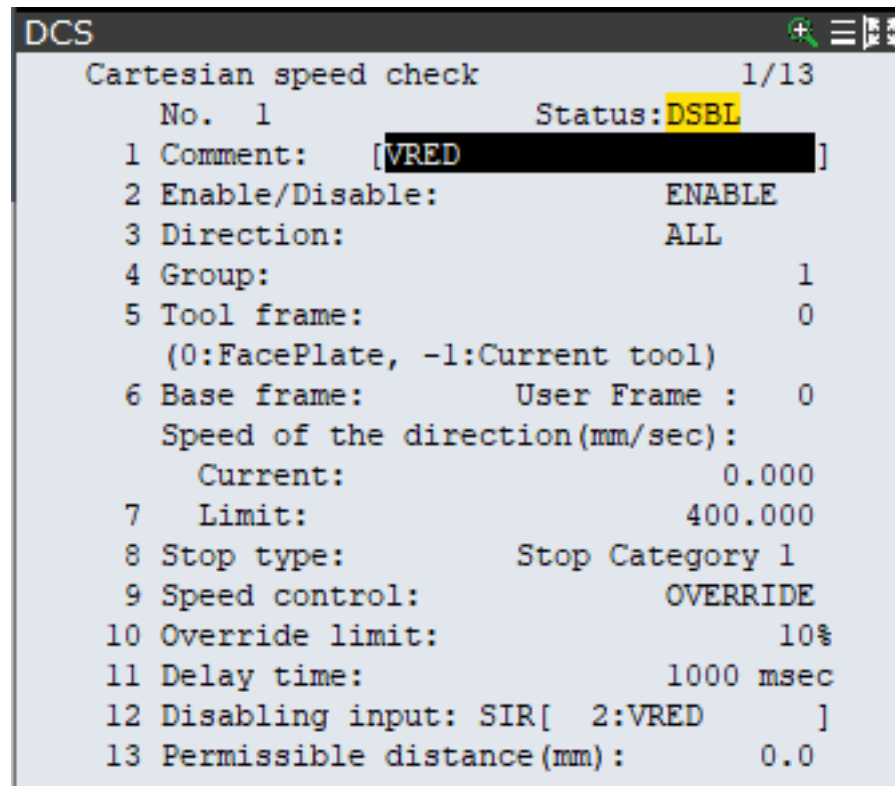
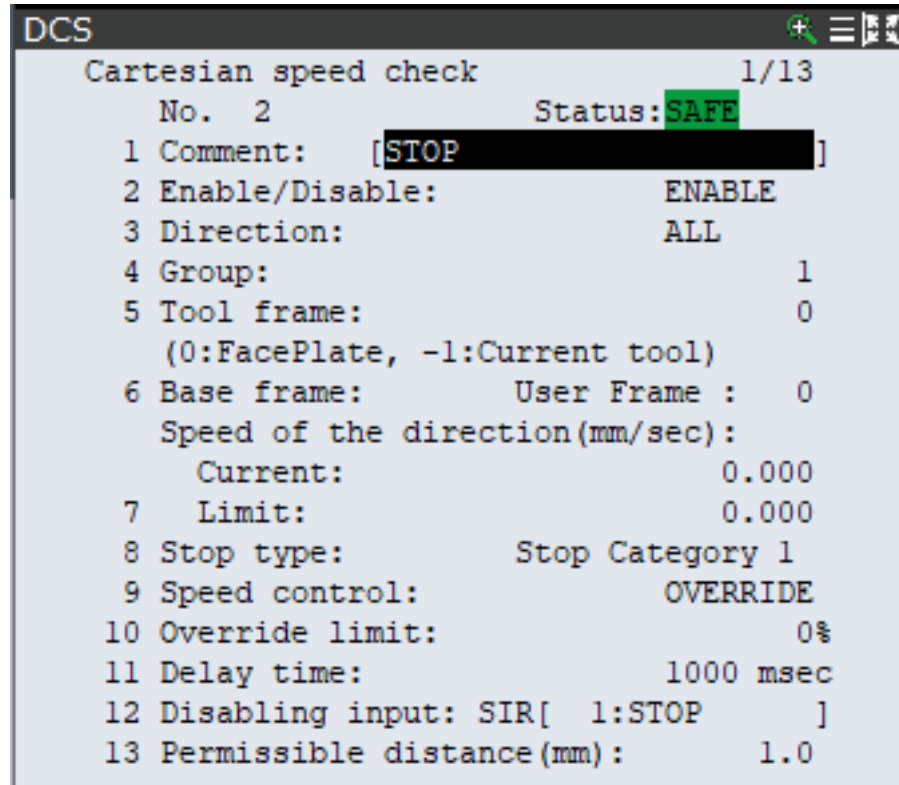

Table 16: Dual check safety > Cartesian speed check no. 2[STOP]

Field	Value
1 Enable/Disable	Enable
2 Direction:	ALL
7 Limit:	0 <sup>3)</sup>
9 Speed control:	OVERRIDE
10 Override limit:	0%
11 Delay time:	1,000 msec <sup>1) 2)</sup>
12 Disabling input:	SIR[1]
13 Permissible distance (mm):	1.0 <sup>1)</sup>

- 1) Example value. The value must be defined by the machine manufacturer and/or integrator.  
2) The value is relevant for calculating the minimum distance of the protective fields to the hazardous area.  
3) If the speed exceeds the limit defined, the robot independently changes to the safe state and displays a corresponding error message.

Example:



The following table describes the configuration of the non-secure signals (see table 13, page 32).

Table 17: MENU > I/O > UOP > IN/OUT

RANGE	RACK	SLOT	START
UI[1-1]	89	2	1
UI[2-2]	89	2	2
UI[3-3]	35	1	1
UI[4-4]	89	2	4
UI[5-5]	89	2	5
UI[6-6]	89	2	6
UI[8-8]	89	2	8

Example:

I/O UOP In							1/9
#	RANGE	RACK	SLOT	START	STAT.		
1	UI [ 1- 1 ]	89	2	1	ACTIV		
2	UI [ 2- 2 ]	89	2	2	ACTIV		
3	UI [ 3- 3 ]	35	1	1	ACTIV		
4	UI [ 4- 4 ]	89	2	4	ACTIV		
5	UI [ 5- 5 ]	89	2	5	ACTIV		
6	UI [ 6- 6 ]	89	2	6	ACTIV		
7	UI [ 7- 7 ]	0	0	0	UNASG		
8	UI [ 8- 8 ]	89	2	8	ACTIV		
9	UI [ 9- 18 ]	0	0	0	UNASG		

Device Name : EthernetIP

[ TYPE ]    MONITOR    IN/OUT    DELETE    ? HELP

## 4.7 Testing plan

The manufacturer of the machine and the operating entity must define all required thorough checks. The definition must be based on the application conditions and the risk assessment.

The following tests must be planned:

- A thorough check must be carried out during commissioning and following modifications.  
The check must detect if it is possible to enter the hazardous area without being detected.
- The regular thorough checks of the safety system must fulfill certain minimum requirements. The minimum requirements for the thorough check of the safety system comply at least with the sum of the minimum requirements for the thorough check of the components of the safety system (see operating instructions of the components).  
The check must detect if it is possible to enter the hazardous area without being detected. Such possibilities may exist due to modifications, manipulations or external influences.
- In many cases, depending on the application conditions, the risk assessment can determine that further thorough checks are required.

The thorough checks must be carried out by qualified safety personnel or specially qualified and authorized personnel, and must be documented in a traceable manner.

The regular thorough checks serve to assess the effectiveness of the safety system and to identify defects as a result of changes or other influences (e.g., damage or manipulation).

## 5 Mounting

### 5.1 For mounting the components

---



**NOTE**

Information is included in the operating instructions for the components.

---

## 6 Electrical installation

### 6.1 Electrical installation of the components

**NOTE**

Information is included in the operating instructions for the components.

### 6.2 General requirements

The manufacturer must take measures against failures resulting from the same cause. The manufacturer must document this appropriately in SISTEMA. During the electrical installation, the following, for example, must be taken into consideration:

- Protection against overvoltage, overcurrent, etc. per the manufacturer instructions for the individual components
- Mechanical fastening of the wiring of the pushbutton for the hold to run device, e.g. with cable ties
- Measures for controlling the consequences of voltage failure, voltage fluctuations, overcurrent and undercurrent in the voltage supply of the robot controller

### 6.3 Safety controller pin assignment

**Important information****NOTE**

The gateway and safety laser scanner have 2 switched connections each. These allow for several connections, also with additional switches.

- Gateway > safety laser scanner > robot controller
- Gateway > robot controller  
Gateway > safety laser scanner
- Gateway > switch  
Safety laser scanner > switch  
Robot controller > switch

Pin assignment

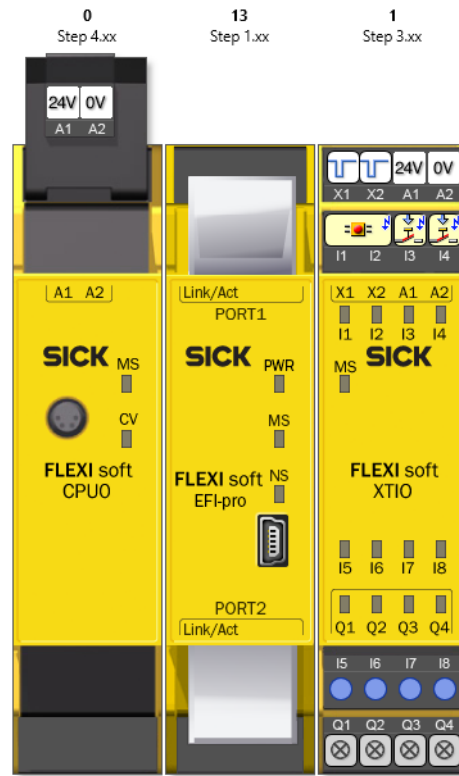

Table 18: Modules of the safety controller

Module 1	FX3-CPU0 main module
Module 2	EFI-pro gateway
Module 3	I/O module FX3-XTIO

Module 1 connections

Table 19: Module 1 connections

Connection	Function
A1	+24 V DC supply voltage
A2	0 V DC supply voltage

Module 2 connections

Table 20: Module 2 connections

Connection	Function
Port 1	Not assigned <sup>1)</sup>
Port 2	Network connection to safety laser scanner and robot

<sup>1)</sup> The gateway has an internal switch. Both connections can be used for mains supply. In this document, it is assumed that port 2 is used for the connection.

Module 3 connections

Table 21: Module 3

Connection	Function
I1	Emergency stop pushbutton
I2	

Connection	Function
I3	Reset pushbutton
I4	Restart button
I5 ... I8	Not assigned
Q1 ... Q4	

## 7 Configuration

### 7.1 Requirements for software and firmware

Table 22: SICK component versions

Software/firmware	Tested version
Safety Designer	1.7.0.39
Firmware FX3-CPU0	4.0
Firmware FX3-GEPR	1.04.0
Firmware FX3-XTIO	3.0
Firmware microScan3 Core EFI-pro	1.0

Table 23: Robot controller versions

Software/firmware	Tested version
Firmware	9.10P / 17
Dual Check Safety (DCS)	4.2.5

### 7.2 Pre-configured project files

SICK provides you with the preconfigured project file in a ZIP archive when you purchase the safety system.

Checksum of the preconfigured project file:

0xDDA6CC5F

### 7.3 Overview of the software structure

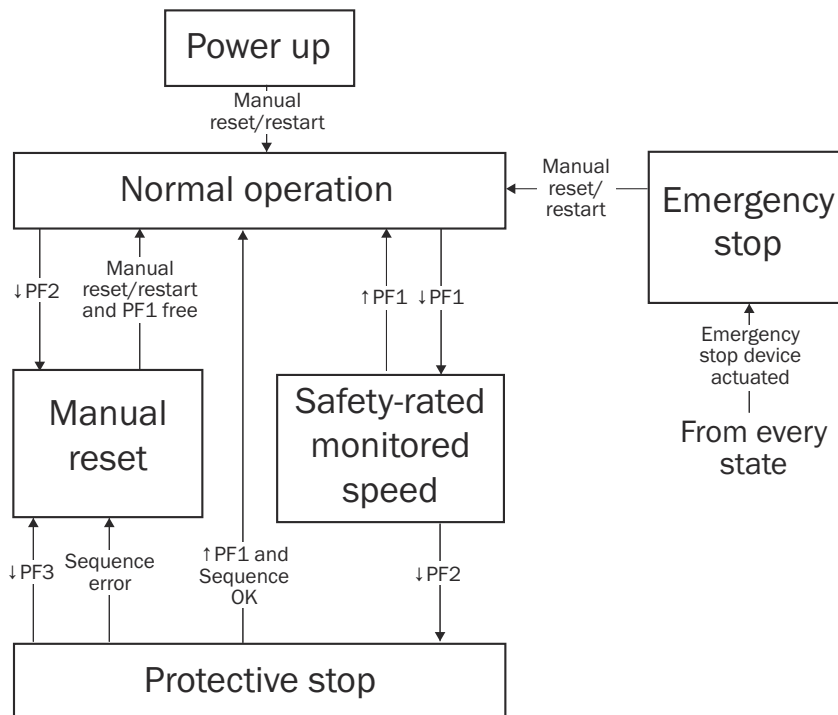

Figure 24: Software structure

↑ Protective field becomes free.  
 ↓ Protective field is interrupted.

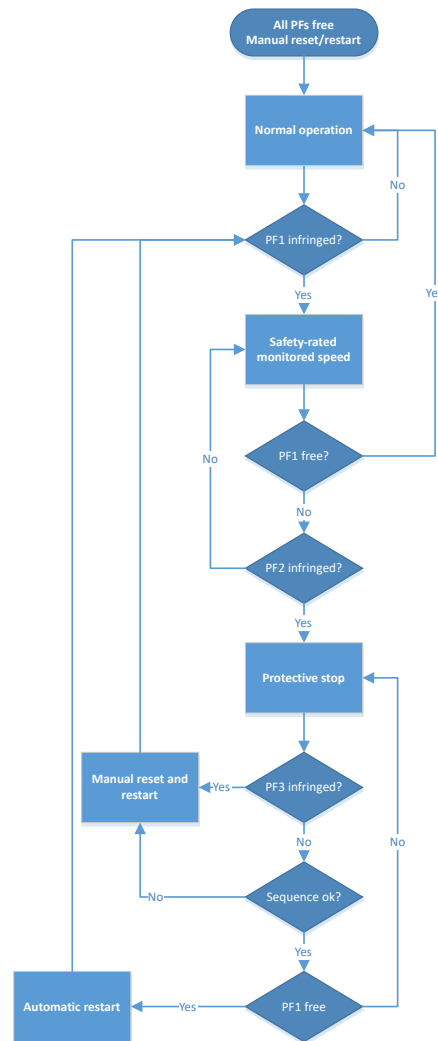

Figure 25: Software logic

## 7.4 Opening project file

1. Start the Safety Designer.
2. Click on **Project**.
3. Click on **Open**.
4. Select the project file.
5. Click on **Open**.
- ✓ The project file opens. The **Settings** view appears.
6. Click on **Configuration**.
- ✓ The device overview view opens.

Double-click on a device to configure that device.

### 7.5 Connection overview

See **Connections** for a connection overview of the configured devices.

Depending on the version of configuration software used, the connection to the robot controller may be displayed as an “EFl-pro”-type connection. However, it is always an EtherNet/IP™ – CIP Safety™ connection.

### 7.6 Main module configuration

#### 7.6.1 Verifying the logic

##### Overview

There is no link in the **logic editor** between the logics and the outputs of the safety controller in the delivered state. If you transmit the logic to the safety controller in the delivery condition, the safety outputs always remain in the safe state.

##### Approach

- ▶ Check whether the logics in the safety requirements of the application are sufficient before outputs of the function blocks are linked to outputs of the safety controller.

#### 7.6.2 Jump addresses

Jump addresses consist of a source jump address and a destination jump address. The destination jump address assumes the same value (HIGH or LOW) as the associated source jump address without a delay.

Among other things, jump addresses are used to connect the various pages of logic with each other.

##### 7.6.2.1 Finding source and destination jump addresses that belong together

##### Approach

1. Right-click on the source or destination jump address.
2. Click **Used on page**.
- ✓ A list of all pages containing elements of the jump address is displayed.
3. Click on the desired page.
- ✓ The desired page is displayed.

#### 7.6.3 In/out page

##### Overview

This page contains all inputs and outputs that no longer interact with the robot controller.

- Cut-off path of the safety laser scanner
- Inputs and outputs for emergency stop pushbutton, reset pushbutton, and restart button on the XTIO expansion module
- Jump addresses for external signals

### Jump addresses for external safety signals

You can use the jump addresses for external safety signals to directly trigger the safety functions on the robot controller (e.g. via additional safety switches). The functionality of the safety system described in this document is not impeded by this. The safety functions with external safety signals are not a part of this safety system and are the responsibility of the manufacturer.

Table 24: Jump addresses for external safety signals

Jump address	Description
EXTERNAL_ESTOP	Signal state LOW triggers the emergency stop on the robot controller.
EXTERNAL_STOP	Signal state LOW triggers the protective stop on the robot controller.
EXTERNAL_VRED	Signal state LOW triggers the safety-rated monitored speed on the robot controller (after the configured delay time).

To connect a jump address with an external safety signal, you must replace the corresponding **Static 1** signal on the **Routing n:n 4** function block with the safety signal.

### Jump addresses for additional safety functions

You can use the status of the safety system for further safety functions via the jump addresses. The functionality of the safety system described in this document is not impeded by this. The additional safety functions are not a part of this safety system and are the responsibility of the manufacturer or integrator.

Table 25: Jump addresses for additional safety functions

Jump address	Description
STATUS_ESTOP	Status of the bit for the emergency stop Signal state LOW means that the emergency stop has been triggered.
STATUS_STOP	Status of the bit for the protective stop Signal state LOW means that the protective stop has been triggered.
STATUS_VRED	Status of the bit for the safety-rated monitored speed Signal state LOW means that the safety-rated monitored speed has been triggered.

To use a jump address for further safety functions, you need to connect the associated output on the **Routing n:n 5** function block with the desired output element for the safety function. You may need to expand the safety controller with an XTIO-type expansion module so that enough outputs are available for the additional safety function.

## 7.6.4 Emergency stop page

This page contains the logic for the emergency stop.

Table 26: Important elements on the emergency stop page

Element	Description
IN_EMERGENCYSTOP	Jump addresses that forward the signal of the emergency stop pushbutton. Signal state LOW triggers the emergency stop on the robot controller.
IN_RESET	Jump addresses that forward the signal of the reset pushbutton. Press the reset pushbutton (Signal LOW-HIGH-LOW, HIGH = 100 ms ... 30 s) to reset the <b>Reset 1</b> function block.

## 7.6.5 Protective stop page

This page contains the logic for the protective stop.

Table 27: Important elements on the protective stop page

Element	Description
PF2_STOP	Jump addresses that forward the signal for the protective field PF2. Signal state LOW triggers the protective stop on the robot controller.
SequenceOK	Jump addresses that forward the signal for a valid sequence for automated restart. Signal state LOW prevents the robot from restarting.
PF3_RESET	Jump addresses that forward the signal for the protective field PF3. Signal state LOW triggers a protective stop on the robot controller and requires manually resetting the safety system.
IN_RESET	Jump addresses that forward the signal of the reset pushbutton. Press the reset pushbutton (Signal LOW-HIGH-LOW, HIGH = 100 ms ... 30 s) to reset the <b>Reset 2</b> function block, when protective field PF1 (jump address PF1_VRED) is free at the same time.

### 7.6.6 SafetyRatedMonitoredSpeed page

This page forwards the signal from protective field PF1 to the jump address ROBOT\_VRED.

### 7.6.7 SafeSequenceMonitoring page

#### Overview

This page contains the logic for monitoring the sequence for automated restart.

#### Principle of operation

Table 28: Important elements on the SafeSequenceMonitoring page

Element	Description
Safe Sequence Monitoring V1.0	Customized function block, password protected Evaluates the signals of protective fields PF1 and PF2, among other things.
SequenceOK	Jump addresses that forward the signal for a valid sequence for automated restart. Signal state LOW triggers the protective stop on the robot controller.  Output on function block <ul style="list-style-type: none"> <li>• HIGH = After resetting the safety system: Sequence for automated restart is valid. No error detected.</li> <li>• LOW = Sequence for automated restart invalid or after switching on the safety controller (before resetting the safety system) Safety state LOW leads to a safe state of the safety output via the network "Triggering protective stop". The robot executes a protective stop. Automated restart is prevented.</li> </ul>
AutomaticRestart	Output on function block When protective field PF1 becomes free and there is a valid sequence for automated restart, a HIGH signal is output for 500 ms via the output. This pulse triggers the automated restart.
Reset required	Output on function block If a manual reset is required, there is a pulsating signal (1 Hz) present at the output.

#### Further topics

- ["Automated restart", page 14](#)

### 7.6.8 Robot safety signals page

#### Overview

This page contains the logic and signals for the safety functions that are triggered on the robot controller.

#### Important information



#### NOTE

Some output elements have not yet been connected with the logic on this page. You must first check whether the logic of the safety system is sufficient for the requirements of your application. Only then can you connect the output elements with the logic.

#### Important elements

Table 29: Important elements on the robot safety signals page

Element	Description
ROBOT_EMG_STOP	Jump address that forwards the logic for the emergency stop. The logic forwards the signal to the bit 0.1 NHE External Emergency Stop of the robot controller.
ROBOT_STOP	Jump address that forwards the logic for the protective stop. The logic forwards the signal to the Bit 0.1 ESTOP of the robot controller as long as the conditions for automated restart and manual restart have been fulfilled after manual resetting.
ROBOT_VRED	Jump address that forwards the signal for the safety-rated monitored speed. The logic forwards the signal to the Bit 0.2 VRED of the robot controller.

#### Non-connected output elements

Output element	Must be connected with:
To FANUC R-30iB Plus:904#2.Bit 0.0 ESTOP	Function block <b>AND 5</b> Output <b>Output 1</b>
To FANUC R-30iB Plus:904#2.Bit 0.1 STOP	Function block <b>AND 12</b> Output <b>Output 1</b>
To FANUC R-30iB Plus:904#2.Bit 0.2 VRED	Function block <b>AND 6</b> Output <b>Output 1</b>

### 7.6.9 Non-secure robot signals page

This page contains the logic and signals for the non-secure functions that are triggered on the robot controller.

Table 30: Important elements on the non-secure robot signals page

Element	Description
IN_RESTART	Jump address that forwards the signal for the restart button. Forwarded to bit 0.5 START of the robot controller. Triggers program start on the robot controller.
IN_RESET	Jump addresses that forward the signal of the reset pushbutton. Forwarded to Bit 0.4 FAULT RESET of the robot controller. Acknowledges the error state on the robot controller.

Element	Description
Static 1	Input element is logical 1. The following bits require a constant signal so that the robot can move: <ul style="list-style-type: none"> <li>• Bit 0.0 IMSTP</li> <li>• Bit 0.1 HOLD</li> <li>• Bit 0.3 CYCLE STOP</li> <li>• Bit 0.7 ENABLE</li> </ul>
Restart 4	Function block Part of the safety function - prevent unexpected restart after an emergency stop.

## 7.7 Configuring the safety laser scanner

### 7.7.1 Resolution of the safety laser scanner

You can find the settings for the resolution under **Navigation > Configuration > Monitoring plane**.

A resolution of 70 mm is configured for the safety laser scanner. You must check whether the resolution is suitable for your application.

You can find information on calculating the minimum resolution in the operating instructions 8021911.

### 7.7.2 Field sets and cut-off paths

You can find the settings for the field sets and cut-off paths under **Navigation > Configuration > Monitoring cases**.

3 field sets are configured for the safety laser scanner. One cut-off path is assigned to each field set.

Table 31: Field set allocation

Field set	Cut-off path	Safety Output
VRED (PF1)	1	1
STOP (PF2)	2	2
RESET (PF3)	3	3

### 7.7.3 Configuring the safety system without protective field PF3

#### Approach

1. In the **Navigation**, click on **Configuration**.
  2. Click on **Monitoring cases**.
  3. Under **Field sets** in the area **Defined cut-off behaviour**, click and hold the **Always ON** button.
  4. Drag and drop the **Always ON** button into the working range and over the **RESET PF3** field set (under **Cut-off path 3**).
- ✓ Protective field PF3 is no longer used. The corresponding input element in the logic editor of the main module acts like a static HIGH signal.

## 7.8 Transfer configuration

- ▶ Transmit configuration to the Flexi Soft main module (see operating instructions 8013926).

## 8 Commissioning

### 8.1 Safety



#### WARNING

Hazard due to lack of effectiveness of the protective device

- ▶ Before commissioning the machine, make sure that the machine is first checked and released by qualified safety personnel.
- ▶ Only operate the machine with a perfectly functioning protective device.



#### DANGER

Dangerous state of the machine

During commissioning, the machine or the protective device may not yet behave as you have planned.

- ▶ Make sure that there is no-one in the hazardous area during commissioning.

Before commissioning can be performed, project planning, mounting, electrical installation and configuration must be completed in accordance with this document.

### 8.2 Overview of commissioning

#### Overview

This document gives an overview of the procedure when commissioning and the order of the configurations required for commissioning.

The configuration of the safety system is saved in a project file for the Safety Designer configuration software. The project file contains the configuration for the Flexi Soft safety controller and microScan3 Core EFI-pro safety laser scanner. So that the safety system can function as described in this document, you must also make the settings on the robot controller.

#### Prerequisites

- All cables connected (network and power)
- Safety Designer configuration software installed on the computer

#### Approach

1. Connect safety controller, safety laser scanner, and robot controller to the power supply.
2. Connect safety controller to the computer.
3. Open the project file for the safety system with the Safety Designer configuration software.  
"Opening project file", page 43
4. Configure the IP address of the safety controller, safety laser scanner, and robot controller (customized element).

Table 32: Pre-set IP addresses

Device	IP address
FX3-CPU0	192.168.1.2
mS3 Core EFI-pro	192.168.1.3
FANUC R-30iB Plus	192.168.1.10

5. Finish configuration of the logic of the safety controller.

Note: The connection to the safety controller must be disconnected when doing so.

["Robot safety signals page", page 47](#)

6. Transmit configuration to the safety controller (see operating instructions 8013926).
7. Configure the protective fields for the safety laser scanner (see operating instructions 8021911).
8. Configure the robot controller.  
["Configuration of the robot controller", page 33](#)
9. Put the robot controller into operation.  
["Putting the robot controller into operation", page 50](#)
10. Configure the Safety Network Number (SNN) via the configuration software.  
["Configuring the safety network number in the robot controller", page 55](#)
11. Ensure that all components in the entire system are connected to one another and data exchange is taking place (EtherNet/IP™ – CIP Safety™ and EtherNet/IP™).  
[see "Checking the network connection", page 58](#)
12. Configure individual parameters, such as delay time or permissible distance, according to the application's requirements.  
[see table 15, page 34](#)  
[see table 16, page 35](#)
13. Verifying and validating the safety functions.  
["Checklists", page 66](#)

### 8.3 Putting the robot controller into operation

#### Important information



#### NOTE

- Only qualified personnel are allowed to perform commissioning of the robot controller.
- Changing safety-relevant parameters requires confirming via the **APPLY** button, confirming the report, and then restarting the robot controller.

#### Approach

##### Setting the IP address

1. Select **MENU > 6 SETUP > Host Comm.**
2. Select report **TCP/IP** and click on **DETAIL**.
3. Click on **PORT**.
- ✓ The settings for Port#2 are displayed.
4. Perform the following settings:

Table 33: Port#2 network connection

Field	Value
Port#2 IP addr:	192.168.1.10
Subnet mask:	255.255.255.0
Router IP addr:	192.168.1.2

Example:

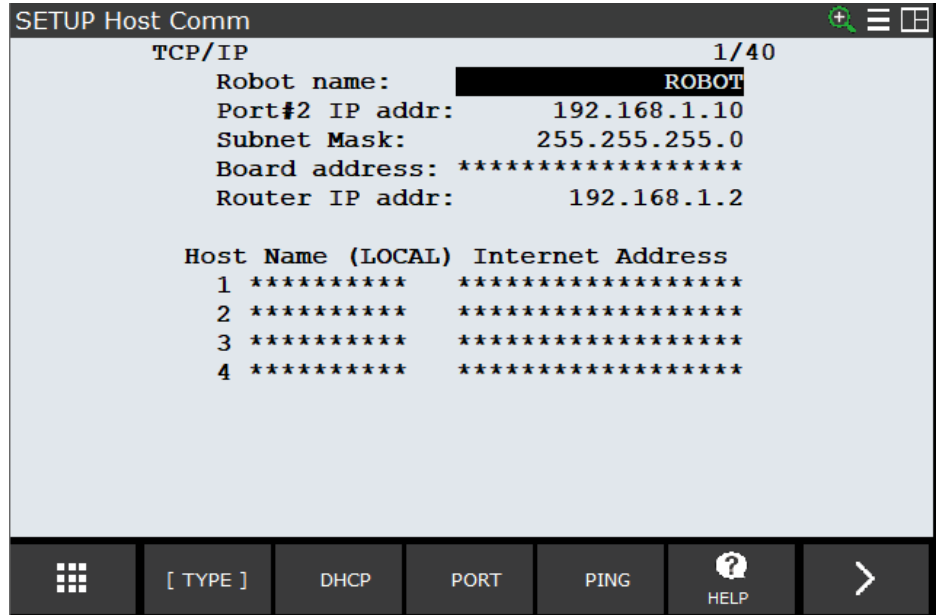

Activate CIP Safety

5. Select **MENU > 0 -- NEXT -- > 6 System > DCS.**
6. Select **CIP Safety** and click on **DETAIL.**
7. Perform the following settings:

Table 34: DCS CIP Safety

Field number	Field	Value
1	Enable/Bypass:	ENABLE
2	CIP Safety input size (byte):	8
3	CIP Safety output size (byte):	8

Example:

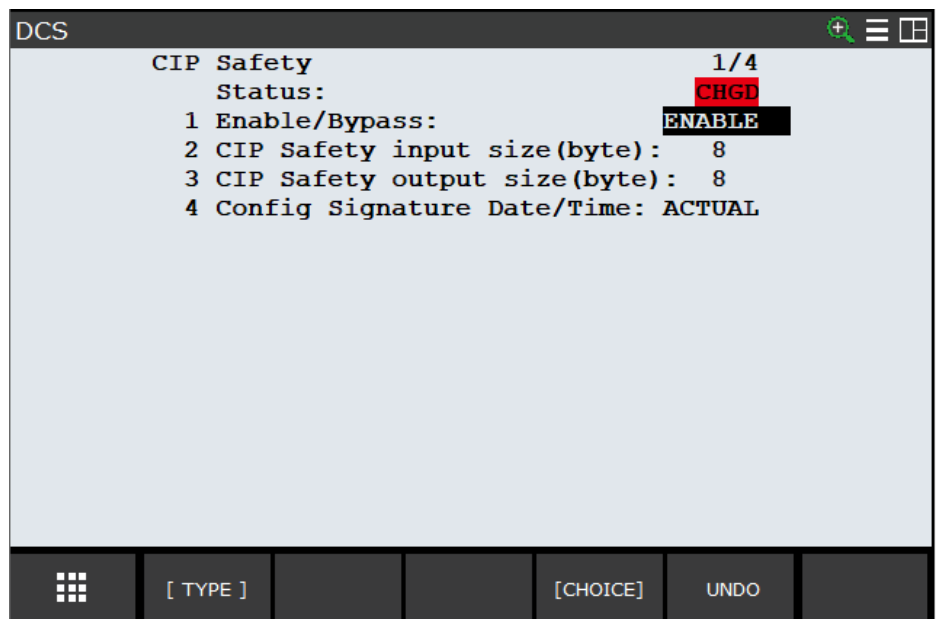

Activate Port#2

8. Select MENU > 5 I/O > Ethernet/IP.
9. Select Connection1 and click on SAFETY.
10. Click on [CHOICE].
11. Select 2 Port 2.

Example:

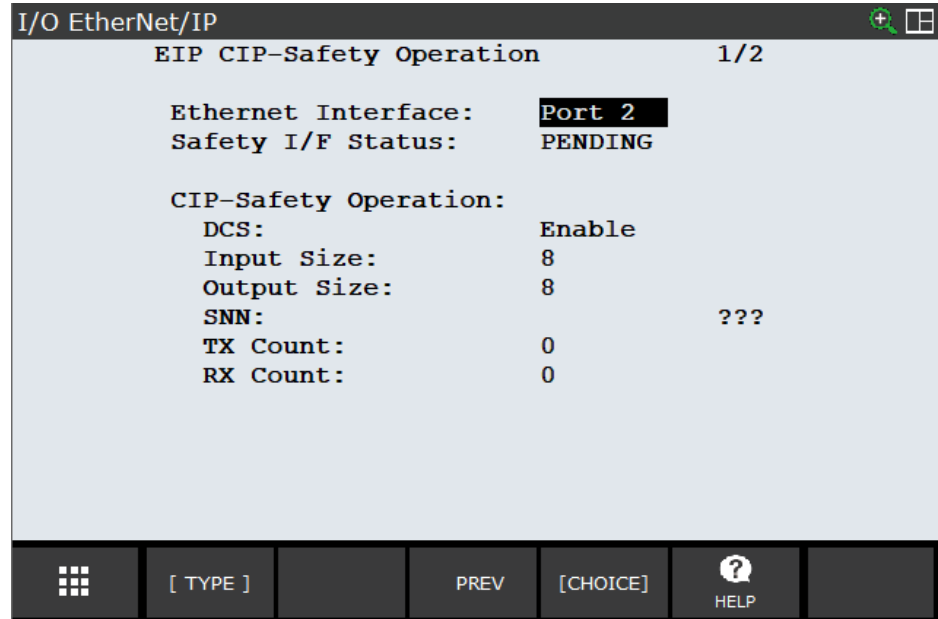

Configure the robot controller as a scanner (master) for non-secure network communication

12. Select MENU > 5 I/O > 5 Ethernet I/P.
13. Select Connection2.
14. In the Enable column, set the value to FALSE so that the connection can be edited.
15. Perform the following settings:

Table 35: I/O Ethernet/IP

Column	Value
Description	EIP_NONSAFE
TYPE	SCN (Scanner)

16. Select EIP\_NONSAFE
17. Click on [CONFIG].
18. Perform the following settings:

Table 36: I/O Ethernet/IP

Field	Value
Name/IP address:	192.168.1.2
Vendor ID:	808
Device type:	100
Product code:	10560
Input size (words):	4
Output size (words):	4
RPI (ms):	32
Assembly instance (input):	140

Field	Value
Assembly instance (output):	130
Configuration instance:	1278

19. Click on **ADV**.
20. Perform the following settings:

Table 37: I/O Ethernet/IP > ADV (advanced settings)

Field	Value
I/O Data Type:	8-Bit Bytes
Timeout Multiplier:	4
Reconnect:	FALSE
Major Revision:	1
Minor Revision:	2
Alarm Severity:	STOP
Quick Connect:	FALSE
Originator To Target RPI:	32
Target To Originator Transport Type:	MULTICAST
Target To Originator RPI:	32
Connection type O=>T Format:	Run/Idle Header
Connection type T=>O Format:	Run/Idle Header

Example:

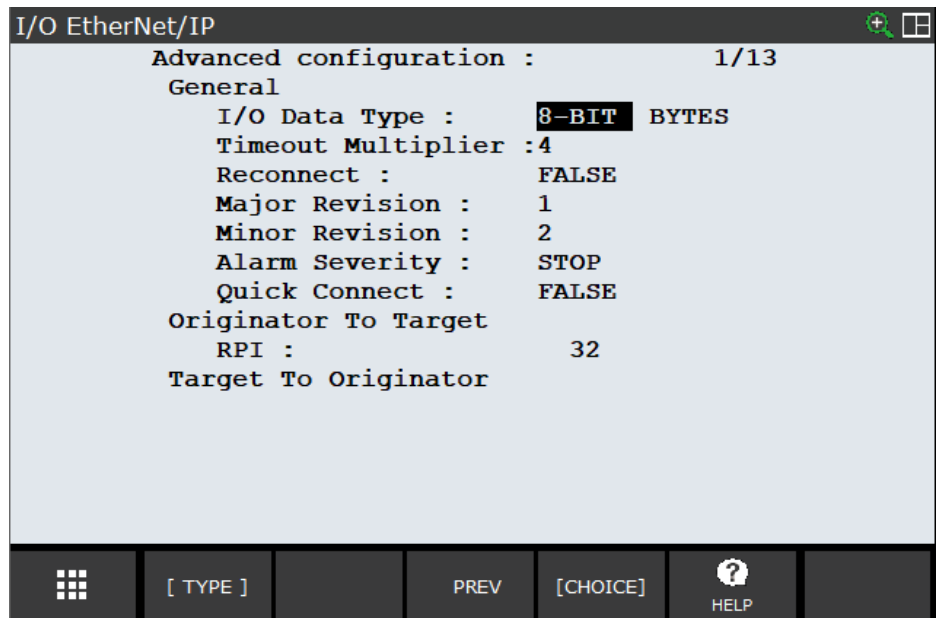

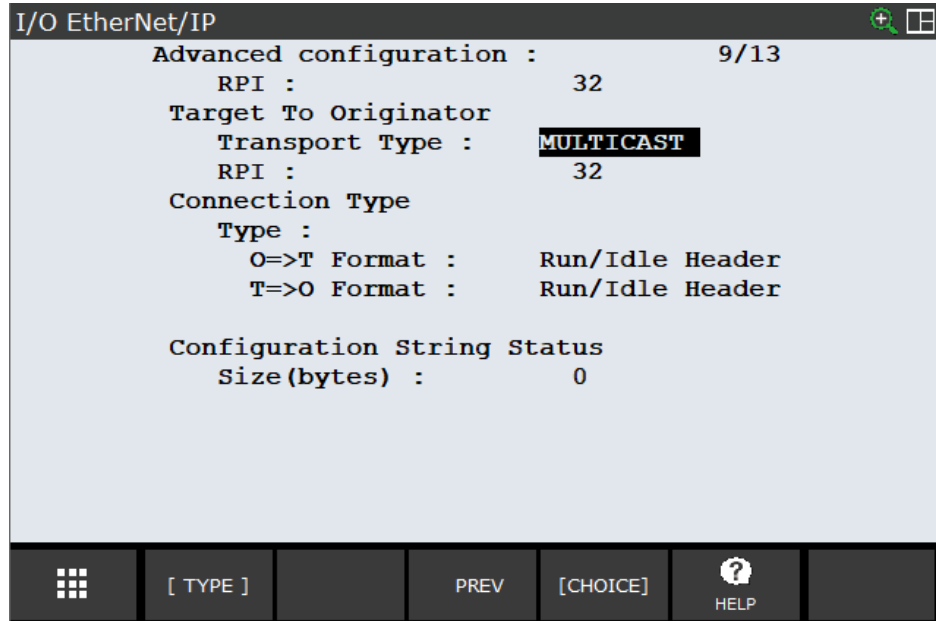

21. On the teach panel, press PREV twice to return to the overview page of the connections.
22. Select **EIP\_NONSAFE**.
23. In the **Enable** column, set the value to **TRUE**.

Activate UOP signals

24. Select **MENU > 0 -- NEXT -- > 6 SYSTEM > Config**.
25. Perform the following settings:

Table 38: System/Config

Field number	Field	Value
7	Enable UI signals	TRUE
42	Remote/local setup:	Remote
64	Zero % Override	TRUE

Example:

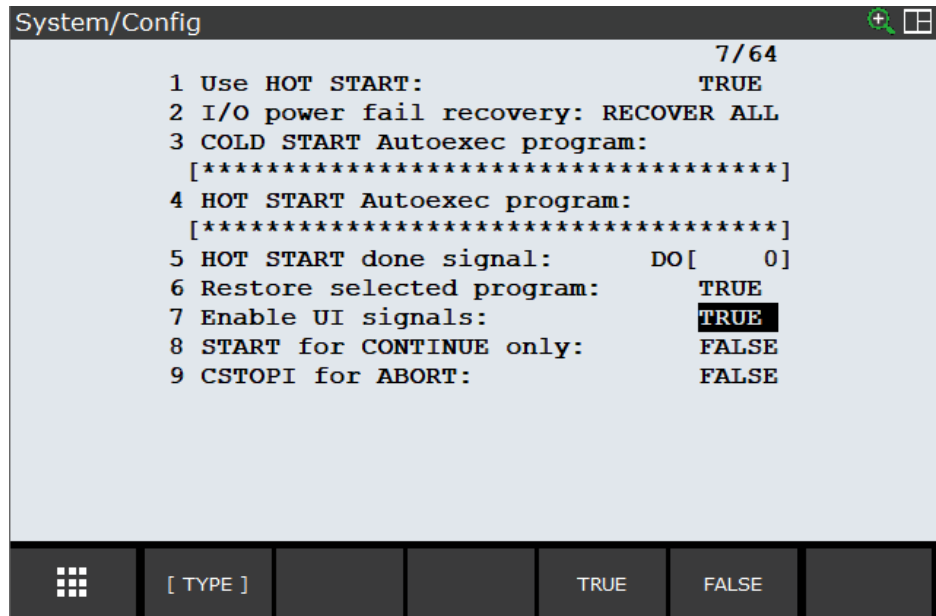

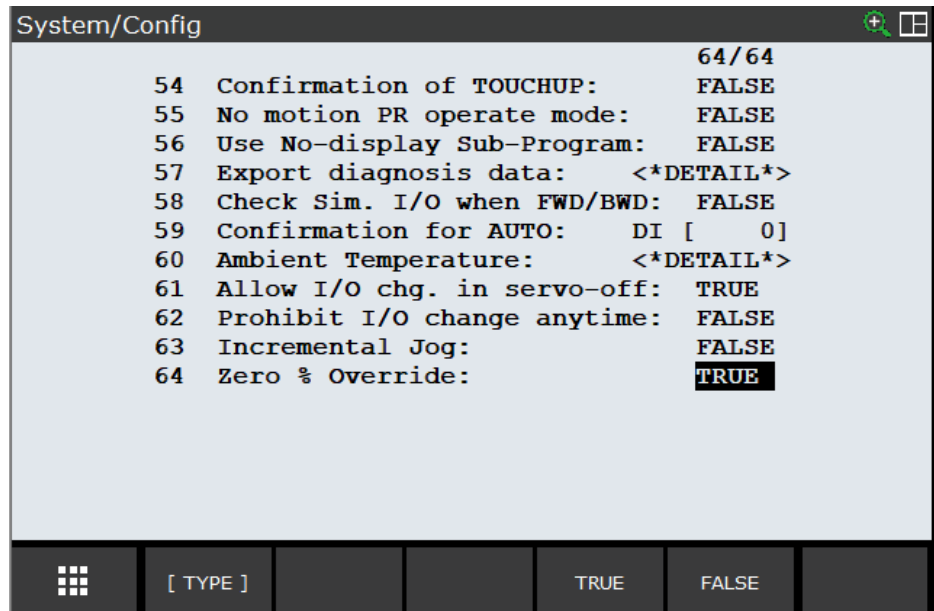
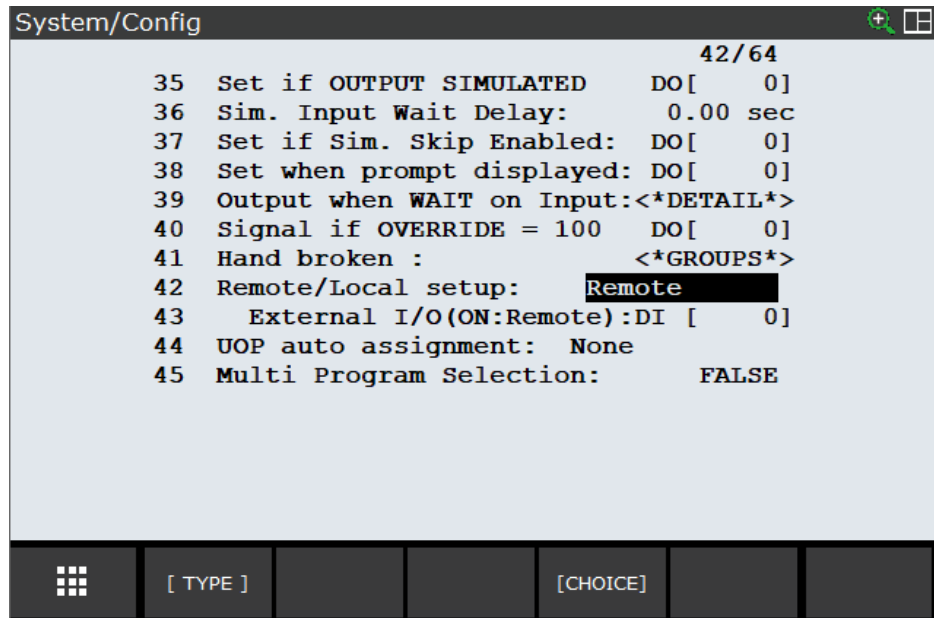

## 8.4 Configuring the safety network number in the robot controller

### Overview

You cannot directly configure the Safety Network Number (SNN) via the user interface of the robot controller. The robot controller receives the Safety Network Number via a manual network service.

### Prerequisites

- The safety controller and robot controller must be switched on.
- The safety controller and robot controller must be connected to the network.

### Approach

1. Open the project file in the Safety Designer configuration software.
2. Click on **Configuration**.

3. Double-click on device **FX3-CPU0**.
4. Click on **Configuration**.
5. In the **Navigation** under **GEPR**, click on **EtherNet/IP services**.
6. Click on the **Services for 3rd party devices** tab.
7. In the **Target IP address** field, enter the IP address of the robot controller (example: 192.168.1.10).
8. Click on **Read from device**.
- ✓ **0x08 Waiting for TUNID** is displayed.  
If **Idle** is displayed, you must first reset the status with the **Safety reset on 192.168.1.10** button.
9. Enter the desired network number in the **Safety network number** field, e.g., 0004\_0000\_000A.
10. Click on **Write TUNID on 192.168.1.10**.
11. Click on **Read from device**.
- ✓ **0x04 Executing** is displayed.

### 8.5 Check during commissioning and modifications

The test is intended to ensure that the hazardous area is monitored by the protective device and that unprotected access to the hazardous area is prevented.

- ▶ Carry out the checks according to the instructions from the manufacturer of the machine and from the operating entity.

## 9 Maintenance

### 9.1 Maintenance of the components

---

**NOTE**

Information is included in the operating instructions for the components.

---

### 10 Troubleshooting

#### 10.1 Troubleshooting the components



---

**NOTE**

Information is included in the operating instructions for the components.

---

#### 10.2 Checking the network connection

##### Approach

##### Check network connection in the safety controller.

1. Connect computer with the safety controller via the network.
2. Start the configuration software.
3. Click **Configuration**.
4. Double-click on safety controller.
5. Click **Configuration**.
6. In the **Navigation** under **GEPR**, click on **Connection overview**.
7. Read off the connection status in the **Connection Status** column.
- ✓ Existing connection are marked with the **established** entry.

##### Check the network connection in the robot controller.

8. Select **MENU > 5 I/O > EtherNet I/P**.
9. Read off the connection status in the **Status** column.
- ✓ If there is an existing network connection, the first connection is marked with the **ONLINE** entry, the second connection with the **RUNNING** entry.
10. Select **Connection 1** and click on **SAFETY**.
- ✓ The existing connection is displayed under **Safety I/F Status** with the entry **Running**.

## **11**      **Operation**

### **11.1**      **Operating the components**

**NOTE**

Information is included in the operating instructions for the components.

---

### **11.2**      **Regular thorough check**

The test is intended to ensure that the hazardous area is monitored by the protective device and that unprotected access to the hazardous area is prevented.

- ▶ Carry out the checks according to the instructions from the manufacturer of the machine and from the operating entity.

## 12 Technical data

### 12.1 Data sheet

Table 39: Data sheet for sBot Speed CIP

Performance level	d
SIL claim limit	2
Supply voltage $V_S$	24 V DC (16.8 V DC ... 30 V DC) (PELV) <sup>1)</sup>
Ambient operating temperature	-10 °C ... 50 °C
Storage temperature	-25 °C ... 70 °C
Air humidity	90% at 50 °C (EN 61131-2)
Permissible operating height	2,000 m
Safe state	The safety outputs via the network are logic 0.

<sup>1)</sup> The external supply voltage must jumper a brief power failure of 20 ms as specified in IEC 60204-1. Suitable power supply units are available as accessories from SICK.

### 12.2 Response time of safety system

#### Composite response time

The response time of the safety system  $t_{\text{SafetySystem}}$  is calculated as follows

$$t_{\text{safetysystem}} = t_{\text{input}} + t_{\text{logic}} + t_{\text{output}}$$

$t_{\text{input}}$	Response time for the input of the gateway including the response time of the safety laser scanner via EFI-pro. Consists of: <ul style="list-style-type: none"> <li>• Response time of the safety laser scanner via EFI-pro <sup>1)</sup></li> <li>• Network response time for data to the gateway <sup>1)</sup></li> <li>• 2 x internal update interval for data from the gateway to the main module <sup>1)</sup></li> <li>• General supplement: +5 ms</li> <li>• Deduction when using a 2nd gateway: -4 ms <sup>2)</sup></li> </ul>
$t_{\text{logic}}$	2 x logic response time of the safety controller
$t_{\text{output}}$	Response time for the output of the gateway. Consists of: <ul style="list-style-type: none"> <li>• 2 x internal update interval for data from the main module to the gateway <sup>1)</sup></li> <li>• Network response time for data from the gateway to the robot controller <sup>1)</sup></li> <li>• General supplement: +8 ms</li> <li>• Deduction when using a 2nd gateway: -4 ms <sup>2)</sup></li> </ul>

<sup>1)</sup> You can find the value in the Safety Designer report.

<sup>2)</sup> Only relevant if an additional gateway is integrated in the safety controller.

#### Complementary information

Changing the components of the safety system, the settings of the EFI-pro network, or the logic program of the safety controller can affect the response time of the safety system. You may have to recalculate the response time of the safety system.

You must also take into account other times when calculating the stopping time of the entire system. The following times are always relevant for the stopping time of the entire system:

- Robot controller response time
- Response time of the robot
- Robot stopping/run-down time

## 13 Ordering information

### 13.1 Ordering information and scope of delivery

Table 40: Ordering information and scope of delivery sBot Speed CIP – FA

	Only hardware	Only software
<b>Part number</b>	<b>1105347</b>	<b>1614143</b>
<b>Hardware</b>		
Safety controller Flexi Soft		
Main module CPU0	1 ×	-
System plug for CPU0	1 ×	-
Extension module XTIO (8 Inputs, 4 Outputs)	1 ×	-
Flexi Soft Gateway FX3-GEPRO	1 ×	-
Safety laser scanner		
microScan3 Core EFI-pro MICS3-ABAZ55ZA1P01	1 ×	-
<b>Software</b>		
Files <sup>1)</sup>	-	1 ×
	<ul style="list-style-type: none"> <li>• Logik configuration (example)</li> <li>• SISTEMA project file</li> <li>• Circuit diagram</li> <li>• Operating instructions</li> </ul>	

<sup>1)</sup> Provided upon purchase of the software.

### 13.2 Ordering information

You must order the hardware and software separately.

Table 41: Hardware sBot Speed CIP ordering information

Description	Part number
Safety system sBot Speed CIP hardware package	1105347

Table 42: Software sBot Speed CIP – FA ordering information

Description	Part number
Safety system sBot Speed CIP – FA software package	1614143

## 14 Accessories

### 14.1 Connectivity

#### Overview

The quantity and type of cables required for operation and configuration depends on the network structure.

Table 43: Cables required

Cable	Network structure		
	Gateway > safety laser scanner > robot controller	Gateway > robot controller Gateway > safety laser scanner	Gateway > switch Safety laser scanner > switch
Cables for operation			
Connecting cable, M12, 4-pin, A-coding	1 ×	1 ×	1 ×
Ethernet cable, M12, 4-pin, D-coding on RJ45	2 ×	1 ×	1 ×
Ethernet cable, D-coding on RJ45, D-coding on RJ45 <sup>1</sup>	–	1 ×	2 ×
Cables for configuration			
<ul style="list-style-type: none"> <li>You need at least one suitable cable.</li> <li>You can connect the safety system via the gateway, via the safety laser scanner, or via an optional switch. The type of cable therefore depends on which device you would like to use to configure the safety system.</li> <li>In any case, the configuration option of connecting the safety laser scanner via USB is very helpful for commissioning and diagnostics.</li> </ul>			
USB mini-B male connector, 3 m cable, USB A male connector	Suitable	Suitable	Suitable
Male connector, straight, 2 m cable, RJ45 male connector	Not suitable	Suitable	Suitable
Ethernet cable, D-coding on RJ45, D-coding on RJ45 <sup>1</sup>	Suitable	Suitable	Suitable

<sup>1</sup> Not available from SICK

#### Connectivity for safety laser scanner supply

Table 44: Ordering information for connecting cable, M12, 4-pin, A-coding

Part	Type code	Part number
Female connector, angled, 5 m cable, flying leads	DOL-1204W05MC75KM0	2079294
Female connector, angled, 10 m cable, flying leads	DOL-1204W10MC75KM0	2079295
Female connector, angled, 20 m cable, flying leads	DOL-1204W20MC75KM0	2089704
Female connector, straight, 5 m cable, flying leads	DOL-1204G05MC75KM0	2079291

Part	Type code	Part number
Female connector, straight, 10 m cable, flying leads	DOL-1204G10MC75KM0	2079292
Female connector, straight, 20 m cable, flying leads	DOL-1204G20MC75KM0	2089703

**Connectivity for network connection**

**Cables for configuration**

Table 45: Ordering information for configuration cables

Part	Part number
USB mini-B male connector, 3 m cable, USB A male connector	6042517
Male connector, straight, 2 m cable, RJ45 male connector	6047916

**14.2 Emergency stop and reset pushbutton**

Table 46: Emergency stop and reset pushbutton

Description	Type code	Part number
Emergency stop with reset pushbutton	ES11-SC4D8	6051329
Emergency stop pushbutton	ES21-SA10E1	6036147
Emergency stop pushbutton	ES21-SB10E1	6041507
Reset pushbutton	ER12-SB3C4	6051330

## 15 Spare parts

### 15.1 sBot Speed CIP spare parts

Table 47: Ordering data for sBot Speed CIP spare parts

Product	Type code	Part number
Flexi Soft safety controller main module	FX3-CPU000000	1043783
Flexi Soft safety controller expansion module - I/O module (8 inputs, 4 outputs)	FX3-XTIO84002	1044125
Flexi Soft EFI-pro gateway safety controller	FX3-GEPR00000	1069070
Flexi Soft safety controller system plug	FX3-MPL000001	1043700
microScan3 core EFI-pro safety laser scanner	MICS3-ABAZ55ZA1P01	1092538

## 16 Annex

### 16.1 Checklists

#### 16.1.1 Checklist for initial commissioning and commissioning

##### Overview

This checklist should be retained and kept with the machine documentation to serve as reference during recurring thorough checks.

This checklist is not a substitute for initial commissioning or periodic thorough checks by qualified safety personnel.

##### Test for emergency situation (emergency stop) safety function

Table 48: Test for emergency situation (emergency stop) safety function

Test sequence	Expected result	Result OK?
1. Start the robot in “Automated” operating mode. 2. Press the emergency stop pushbutton.  Run the test sequence for every emergency stop pushbutton individually.	The safety outputs via the network are LOW. The robot stops.	Yes <input type="checkbox"/> No <input type="checkbox"/>
1. Start the robot in the “Manual, reduced speed” operating mode. 2. Press the emergency stop pushbutton.  Run the test sequence for every emergency stop pushbutton individually.	The safety outputs via the network are LOW. The robot stops.	Yes <input type="checkbox"/> No <input type="checkbox"/>
Note the designations of the tested emergency stop pushbuttons here.		

##### Tests for “Preventing unexpected restart following an emergency stop” safety function

Table 49: Tests for “Preventing unexpected restart following an emergency stop” safety function

Test sequence	Expected result	Result OK?
1. Start the robot in “Automated” operating mode. 2. Press the emergency stop pushbutton. 3. Reset the emergency stop pushbutton. 4. Press the restart button.  Run the test sequence for every emergency stop pushbutton individually.	The robot remains at a standstill. The machine can only be restarted with the restart button after the reset pushbutton has been pressed.	Yes <input type="checkbox"/> No <input type="checkbox"/>
Note the designations of the tested emergency stop pushbuttons here.		

### Tests for the “Protective stop” safety function

Table 50: Tests for the “Protective stop” safety function

Test sequence	Expected result	Result OK?
<ol style="list-style-type: none"> <li>1. Start the robot in “Automated” operating mode.</li> <li>2. Interrupt protective field PF2.</li> <li>3. With protective field PF2 interrupted, change to “Manual, reduced speed” operating mode.</li> <li>4. Actuate the enabling device.</li> <li>5. Press the restart button.</li> </ol>	<p>The robot carries out a protective stop when protective field PF2 is interrupted.</p> <p>The status of the DCS Cartesian speed check function STOP changes to the <b>SAFE</b> state.</p> <p>In the “Manual, reduced speed” operating mode, the robot can also move when the enabling device is actuated while protective field PF2 is interrupted.</p>	Yes <input type="checkbox"/> No <input type="checkbox"/>
<p>Note the settings for the safety-rated monitored speed function (in particular <b>Speed limit</b> and <b>Delay time</b>) here:</p>		

### Tests for “Triggering safety-rated monitored speed” safety function

Table 51: Tests for “Triggering safety-rated monitored speed” safety function

Test sequence	Expected result	Result OK?
<ol style="list-style-type: none"> <li>1. Start the robot in “Automated” operating mode.</li> <li>2. Interrupt protective field PF1.</li> <li>3. With protective field PF1 interrupted, change to “Manual, reduced speed” operating mode.</li> <li>4. Actuate the enabling device.</li> <li>5. Press the restart button.</li> </ol>	<p>The robot reduces its speed.</p> <p>The status of the DCS Cartesian speed check function VRED changes to the <b>SAFE</b> state.</p> <p>In the “Manual, reduced speed” operating mode, the robot can also move when the enabling device is actuated while protective field PF1 is interrupted.</p>	Yes <input type="checkbox"/> No <input type="checkbox"/>
<p>Note the settings for the function for the safety-rated monitored speed (esp. <b>speed limit</b> and <b>delay time</b>) here:</p>		

### Tests for the “Automated reset and restart with safe sequence monitoring” safety function

Table 52: Tests for the “Automated reset and restart with safe sequence monitoring” safety function

Test sequence	Expected result	Result OK?
<ol style="list-style-type: none"> <li>1. Start the robot in “Automated” operating mode.</li> <li>2. Interrupt protective field PF1.</li> <li>3. Interrupt protective field PF2.</li> <li>4. Approve protective field PF2, but continue to interrupt protective field PF1.</li> <li>5. Approve protective field PF1.</li> </ol>	<p>If protective field PF1 is interrupted, the robot reduces its speed. If protective field PF2 is interrupted, the robot stops. If protective field PF1 becomes free again, an automated restart takes place.</p>	Yes <input type="checkbox"/> No <input type="checkbox"/>
<ol style="list-style-type: none"> <li>1. Start the robot in “Automated” operating mode.</li> <li>2. Interrupt protective field PF2 without having first interrupted protective field PF1.</li> </ol>	<p>The robot stops. Restarting is only possible when all protective fields are free and the reset pushbutton has been actuated.</p>	Yes <input type="checkbox"/> No <input type="checkbox"/>

Test sequence	Expected result	Result OK?
<ol style="list-style-type: none"> <li>1. Start the robot in “Automated” operating mode.</li> <li>2. Interrupt protective field PF1.</li> <li>3. Interrupt protective field PF2.</li> <li>4. Stand behind the protective fields or approve protective fields PF1 and PF2 at the same time.</li> </ol>	<p>The robot stops. Restarting is only possible when all protective fields are free and the reset pushbutton has been actuated.</p>	<p>Yes <input type="checkbox"/> No <input type="checkbox"/></p>
<ol style="list-style-type: none"> <li>1. Open the configuration of the safety laser scanner in the configuration software.</li> <li>2. Connect the safety laser scanner with the computer and read out the current field sets.</li> <li>3. Determine the distance between the protective fields PF1 and PF2 at the transition to the hazardous area.</li> <li>4. Check the protective field dimensions.</li> </ol>	<p>The protective fields of the safety laser scanner overlap as described in the corresponding chapter. <a href="#">"Overlapping protective fields", page 23</a></p>	<p>Yes <input type="checkbox"/> No <input type="checkbox"/></p>
<p>Comments:</p>		

**Tests for “Manual reset and a manual restart” safety function**

Table 53: Tests for “Manual reset and a manual restart” safety function

Test sequence	Expected result	Result OK?
<ol style="list-style-type: none"> <li>1. Start the robot in “Automated” operating mode.</li> <li>2. Interrupt protective field PF3. If protective field PF3 is not configured, trigger a sequence error. Continue to interrupt protective field PF1 when doing so.</li> <li>3. Actuate the reset pushbutton.</li> <li>4. Actuate the restart button.</li> <li>5. Approve protective field PF1.</li> <li>6. Actuate the restart button.</li> <li>7. Actuate the reset pushbutton.</li> <li>8. Actuate the restart button.</li> </ol>	<p>Restarting the robot is not possible as long as protective field PF1 is interrupted.</p> <p>The robot cannot restart without resetting. After actuating the reset pushbutton and the restart button, the robot starts up.</p> <p>After interrupting protective field PF3, manual resetting is still necessary even after a valid sequence,</p>	<p>Yes <input type="checkbox"/> No <input type="checkbox"/></p>
<p>Comments:</p>		







**Australia**

Phone +61 (3) 9457 0600  
1800 33 48 02 – tollfree  
E-Mail sales@sick.com.au

**Austria**

Phone +43 (0) 2236 62288-0  
E-Mail office@sick.at

**Belgium/Luxembourg**

Phone +32 (0) 2 466 55 66  
E-Mail info@sick.be

**Brazil**

Phone +55 11 3215-4900  
E-Mail comercial@sick.com.br

**Canada**

Phone +1 905.771.1444  
E-Mail cs.canada@sick.com

**Czech Republic**

Phone +420 234 719 500  
E-Mail sick@sick.cz

**Chile**

Phone +56 (2) 2274 7430  
E-Mail chile@sick.com

**China**

Phone +86 20 2882 3600  
E-Mail info.china@sick.net.cn

**Denmark**

Phone +45 45 82 64 00  
E-Mail sick@sick.dk

**Finland**

Phone +358-9-25 15 800  
E-Mail sick@sick.fi

**France**

Phone +33 1 64 62 35 00  
E-Mail info@sick.fr

**Germany**

Phone +49 (0) 2 11 53 010  
E-Mail info@sick.de

**Greece**

Phone +30 210 6825100  
E-Mail office@sick.com.gr

**Hong Kong**

Phone +852 2153 6300  
E-Mail ghk@sick.com.hk

**Hungary**

Phone +36 1 371 2680  
E-Mail ertekezes@sick.hu

**India**

Phone +91-22-6119 8900  
E-Mail info@sick-india.com

**Israel**

Phone +972 97110 11  
E-Mail info@sick-sensors.com

**Italy**

Phone +39 02 27 43 41  
E-Mail info@sick.it

**Japan**

Phone +81 3 5309 2112  
E-Mail support@sick.jp

**Malaysia**

Phone +603-8080 7425  
E-Mail enquiry.my@sick.com

**Mexico**

Phone +52 (472) 748 9451  
E-Mail mexico@sick.com

**Netherlands**

Phone +31 (0) 30 229 25 44  
E-Mail info@sick.nl

**New Zealand**

Phone +64 9 415 0459  
0800 222 278 – tollfree  
E-Mail sales@sick.co.nz

**Norway**

Phone +47 67 81 50 00  
E-Mail sick@sick.no

**Poland**

Phone +48 22 539 41 00  
E-Mail info@sick.pl

**Romania**

Phone +40 356-17 11 20  
E-Mail office@sick.ro

**Russia**

Phone +7 495 283 09 90  
E-Mail info@sick.ru

**Singapore**

Phone +65 6744 3732  
E-Mail sales.gsg@sick.com

**Slovakia**

Phone +421 482 901 201  
E-Mail mail@sick-sk.sk

**Slovenia**

Phone +386 591 78849  
E-Mail office@sick.si

**South Africa**

Phone +27 10 060 0550  
E-Mail info@sickautomation.co.za

**South Korea**

Phone +82 2 786 6321/4  
E-Mail infokorea@sick.com

**Spain**

Phone +34 93 480 31 00  
E-Mail info@sick.es

**Sweden**

Phone +46 10 110 10 00  
E-Mail info@sick.se

**Switzerland**

Phone +41 41 619 29 39  
E-Mail contact@sick.ch

**Taiwan**

Phone +886-2-2375-6288  
E-Mail sales@sick.com.tw

**Thailand**

Phone +66 2 645 0009  
E-Mail marcom.th@sick.com

**Turkey**

Phone +90 (216) 528 50 00  
E-Mail info@sick.com.tr

**United Arab Emirates**

Phone +971 (0) 4 88 65 878  
E-Mail contact@sick.ae

**United Kingdom**

Phone +44 (0)17278 31121  
E-Mail info@sick.co.uk

**USA**

Phone +1 800.325.7425  
E-Mail info@sick.com

**Vietnam**

Phone +65 6744 3732  
E-Mail sales.gsg@sick.com

Detailed addresses and further locations at [www.sick.com](http://www.sick.com)

